



"innovation in its most functional form"

PRODUCT DATA SHEET

SW14.5TI

INTEGRAL HYDRAULIC

FLANGE SPREADER

LIFTING FORCE:

14.5 T (145 kN)

It is recommended that tools are used in pairs
giving $2 \times 14.5 = 29 \text{ T (290 kN)}$

TOOL WEIGHT = 9 kg (19.8 lbs)

KIT COMPONENTS

- 1 x SW14.5TI Wedgehead
 - 1 x 10,000 psi (700 bar) Integral Hydraulic Pump/Cylinder
 - 1 x Safety Block
 - 1 x Pair of Stepped Blocks
 - 1 x Carry-Strap
 - 1 x Instruction Manual
 - 1 x Carry-Case
- Product Code: SW14.5TISPB



WEIGHTS AND DIMENSIONS

- Wedge with Integral Hydraulic Pump Cylinder = 9 kg (19.8 lbs)
- Carry-Case = 2.5 kg (5.5 lbs)
- Gross Weight = 14 kg (28.6 lbs)

Carry-Case Dimensions:
580 x 340 x 180mm (22.8" x 13.4" x 7")

TOOL DIMENSIONS - CLOSED

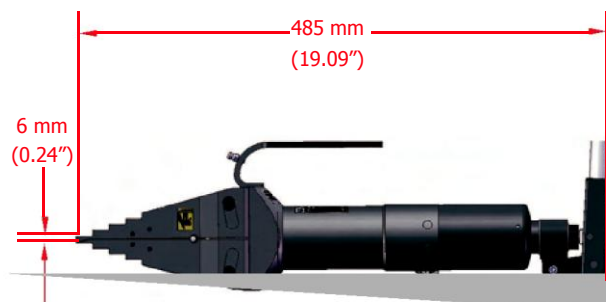

TOOL DIMENSIONS - OPEN

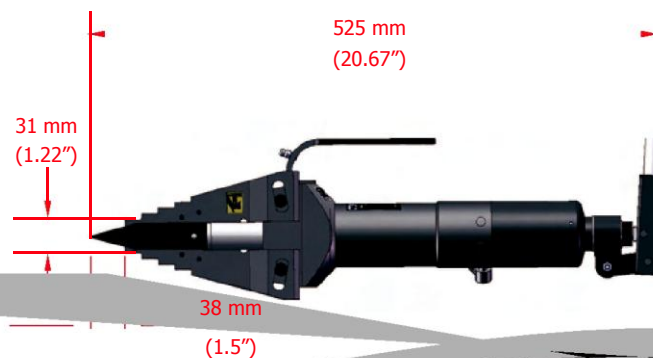

SW14.5TI

INTEGRAL HYDRAULIC FLANGE SPREADER



"Innovation in its most functional form"



TOOL DIMENSIONS - CLOSED



TOOL DIMENSIONS - OPEN

SAFETY BLOCK DIMENSIONS

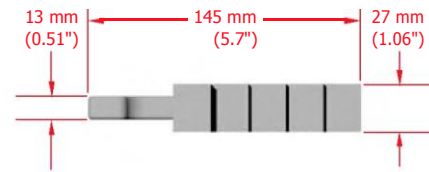
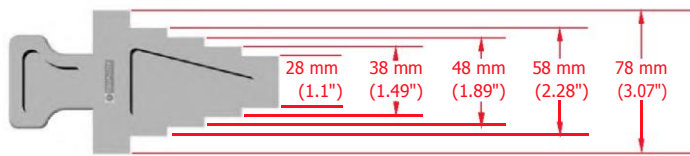

PARTS LIST AND EXPLODED DRAWING

ITEM	PART No.	DESCRIPTION	QUANTITY
01	300203-02	JAWS	01 set of 2
02	300101-01	WEDGE	01 each
03	301301-01	GRUB SCREW	01 each
04	301201-08	ROLL PINS	01 set of 8
05	301102-01	BODY	01 each
06	300501-04	SLIDE PINS	01 set of 4
07	401801-01	RETAINING SCREW	01 each
08	308201-01	HANDLE	01 each
09	312302-01	HANDLE SLEEVE	01 each
10	310601-01	GREASE NIPPLE	01 each
11	311601-02	RING	01 set of 2
12	300401-04	GRUB SCREWS	01 set of 4

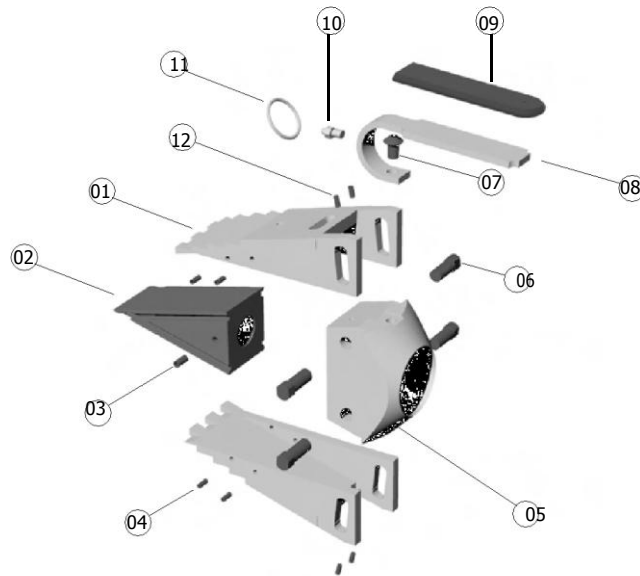

STEPPED BLOCKS

Stepped Blocks can be used singularly or in pairs to increase the maximum spreading distance of the SW14.5TI to 81mm.

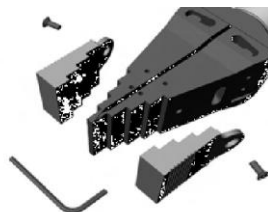

WEIGHTS AND DIMENSIONS

Stepped Block = 0.52 kg (1.14 lb)

GROSS WEIGHT = 1.5 kg (3.5 lb)

