

UNITEC

ELECTRIC • PNEUMATIC • HYDRAULIC

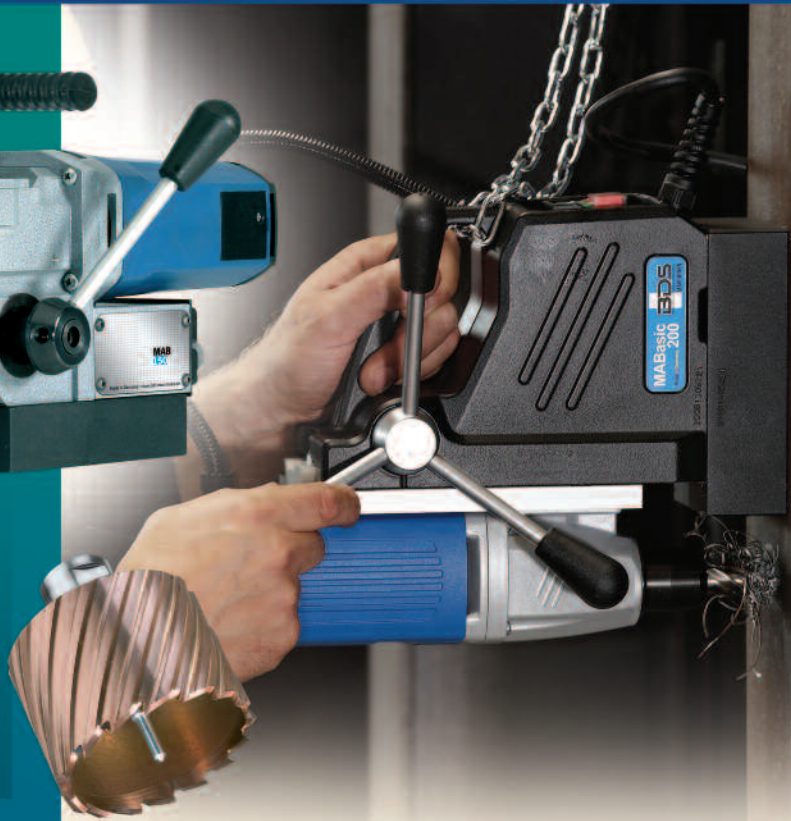

**Hole Cutting • Twist Drilling
Tapping • Reaming**

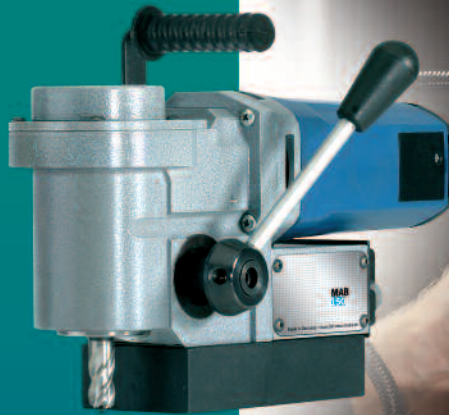

**Magnetic Drills
Annular Cutters
Hand-held Drills
Drive Units
Nut Runners
Beveling Machines**



Portable Magnetic Drilling Machines

PORTABLE MAGNETIC DRILLS

**Fast, accurate hole cutting...
on the job site or in the shop!**



Designed for continuous operation, CS Unitec's portable magnetic drills are ideal for drilling structural steel and virtually any metal. We offer the most compact, powerful and reliable series of portable magnetic drills for holes up to 5-1/8" diameter. All CS Unitec drills are heavy-duty for use in construction and industry. Our complete line includes electric, pneumatic and hydraulic tools. They are available for prompt delivery.

CS Unitec is the industry leader in: *Our drills have unique features:*

- Power-to-weight ratios
- Strongest clamping force with high-density (HD) dual-coil magnets
- Magnetic drills for tapping
- Annular Cutters: TiAlN, HSS, cobalt steel and carbide-tipped
- Longest drill stroke in the industry
- Variable-speed, multiple-gear models
- Electric, pneumatic and hydraulic power
- Reversible motors for tapping
- Swivel base stand for hard-to-reach areas
- Battery-operated for on-site cordless drilling

Rugged construction and sophisticated functionality.



Intuitive magnets, ergonomic controls and simple operation for superior cuts.

Overheating Protection with CoolMag

COOLMAG™ Electromagnets

ensure that the magnet does not overheat. When the magnet is switched on for long periods of time, the coils could overheat or even burn out. The CoolMag feature reduces the power of the magnets when the drill motor is not active. Therefore, it won't build up heat.

CS Unitec high-density dual-coil magnets are ground, not cast, and are wound into two circles to increase the surface area and density of the magnetic field.



Keyless, quick-change system for annular cutters saves time and money. Just twist and lock.



Twist Drilling



Tapping



Reaming



Countersinking

ARMOR-PLATED™ TiAlN Cutters

are ideal for all drilling applications. A high surface hardness and greater lubricity allow for drilling at high operating temperatures with more power and speed.



Custom machines for unique applications

Our engineers can create a drill, drill rig, or other application-specific arrangement to meet your needs.

See page 51 for more information, or call 1-800-700-5919 for design assistance.

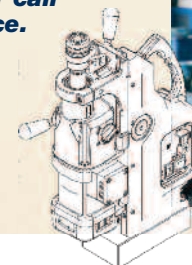
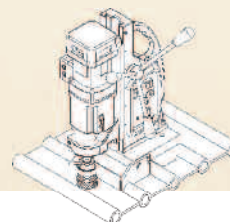
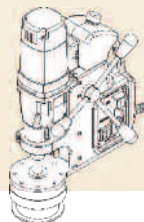

The value is in the engineering...
the payback is in the performance.

IQ Magnetic System for Active Safety

Magnetic force is the key to safety and success.

The magnetic force of your magnet depends on a number of factors:

- ▶ Thickness of material being drilled
- ▶ Coatings or paint layers on material
- ▶ Chips, dirt or grease between the magnet and the material

SafeMag System

Electronic Safety Shutoff Sensor

The **SAFEMAG™ System** measures whether the magnet has sufficient adhesive force on the material. An LED indicator on the switch panel warns you of insufficient magnetic force (**Red Light**) or tells you if the correct force is present (**Green Light**).



LED red... insufficient magnetic force. Drilling should not take place. Possible causes are too-thin material, coatings of paint, scale or zinc.

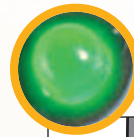
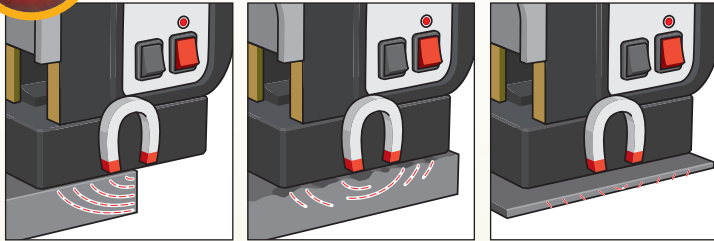

LED green... the magnetic adhesion meets the minimum requirements. Drilling can take place.

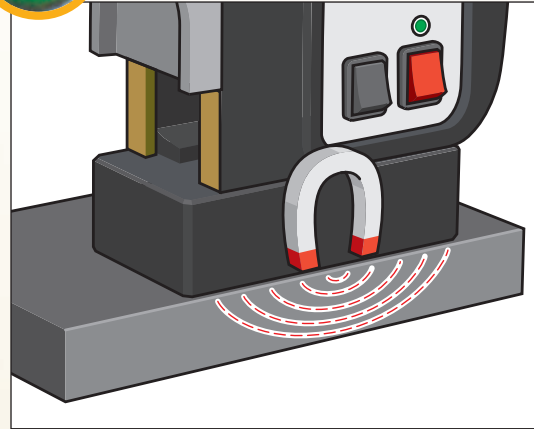

Our **Electronic Safety Shutoff Sensor** automatically shuts down the drill motor if the magnet loses contact with the material. This emergency-off feature helps to protect both operator and equipment.

Integrated cable routing: MAB Series

The new generation of our MAB portable magnetic drilling machines has been developed for increased safety. This includes complete cable routing within the casing.

- ▶ No threading and getting caught
- ▶ No tearing or snapping off

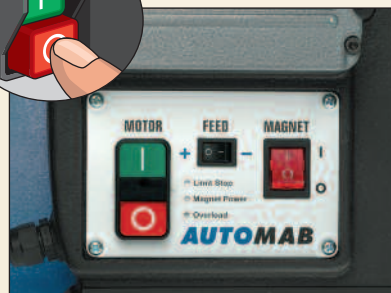
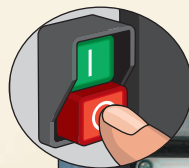
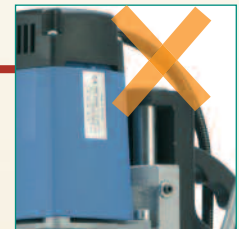

Simple, ergonomic arrangement of controls for one-handed operation. Emergency-off function for quick shutdown.

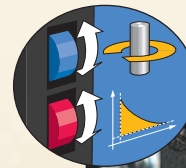

High power at low speeds. Electronic torque control prevents damage to motor.

Portable Magnetic Drills



MDM 40 p. 8
Capacity: \varnothing 1-1/2" cutter



MABasic Series p. 9-11
Capacity: \varnothing 1-1/4" to 3" cutter
Professional grade, versatile



MAB 150 p. 12
Capacity: \varnothing 1-1/2" cutter
For drilling in tight spaces



MAB 455 & MAB 455 SB p. 14
Capacity: \varnothing 2" cutter; \varnothing 7/8" twist drill
Swivel base (MAB 455 SB)
2 speeds



MAB 485 & MAB 485 SB p. 16
Capacity: \varnothing 2" cutter; \varnothing 7/8" twist drill;
 \varnothing 15/16" tapping
Reversible, 2-gear motor
Swivel base (MAB 485 SB)



MAB 525 & MAB 525 SB p. 18
Capacity: \varnothing 2-1/2" cutter; \varnothing 1" twist drill;
 \varnothing 15/16" tapping
Reversible, 2-gear motor
Swivel base (MAB 525 SB)



AutoMAB 1500 & AutoMAB 1500 SB p. 20
Capacity: \varnothing 1-1/2" cutter
Automatic feed
Swivel base (AutoMAB 1500 SB)



MAB 825 KTS p. 21
Capacity: \varnothing 2-3/8" cutter; \varnothing 1" twist drill;
 \varnothing 1-1/8" tapping
Multi-axis positioning for boring, slotting, etc.
Reversible, 4-gear motor



MAB 825, MAB 825 V & MAB 845 p. 22
Capacity: \varnothing 4" cutter; \varnothing 1-1/4" twist drill;
 \varnothing 1-1/8" tapping
Auto feed (MAB 825 V) Swivel base (MAB 845)
Reversible, 4-gear motor



MAB 1300 p. 24
Capacity: \varnothing 5-1/8" cutter
 \varnothing 1-3/4" twist drill
 \varnothing 1-5/8" tapping
Reversible, 4-gear motor
The ultimate in power

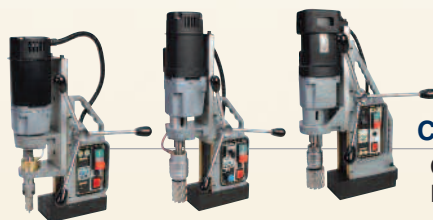

CSU Series p. 27-29
Capacity: \varnothing 1-1/4" to 4" cutter
Reversible for tapping



AIRBOR™ AB-4300 p. 30
Pneumatic power
Capacity: \varnothing 2-1/16" cutter; \varnothing 1/2" twist drill
ATEX for hazardous environments



HB 4400 p. 31
Hydraulic power
Capacity: \varnothing 2-1/16" cutter; \varnothing 1/2" twist drill
For marine, construction and underwater applications

Warranty

Products of CS Unitec, Inc. are warranted to be free from defects in material and workmanship for one year from date of purchase. This warranty does not apply to normal wear or products which have been abused, misused, modified or repaired by someone other than CS Unitec, Inc. or its Authorized Service Representatives.

If a product proves defective in material or workmanship within one year after purchase, return it to CS Unitec, Inc. or an Authorized Service Center, transportation prepaid. CS Unitec, Inc. will, at its option, repair or replace defective products free of charge.

CS Unitec, Inc.'s sole liability and your exclusive remedy under this warranty is limited to repair or replacement of the defective product. There are no other warranties expressed or implied and CS Unitec, Inc. shall not be liable for incidental, consequential or special damages, or expenses excepting only the cost or expense of repair or replacement as described above.

Safety

Operators of any power tool should use appropriate safety precautions for work being performed. This includes safety chains, eye protection, hearing protection, gloves and more. Follow instructions included in operating manual.

Annular Cutters

p. 32-41

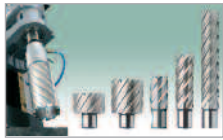

HSS Unibroach® p. 34-35

High-speed steel
7/16" to 5-1/8" diameter
1", 2" and 3" depth
Special sizes available



TiAIN ARMOR-PLATED Unibroach™ p. 36-37

For higher working temperatures
7/16" to 5-1/8" diameter
1", 2" and 3" depth



TCT Hornet p. 38-39

Tungsten carbide-tipped
1/2" to 5-1/8" diameter
1", 2-3/8" and 3-3/8" depth

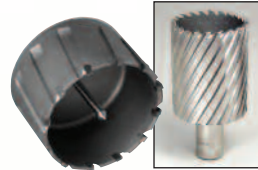

Large-Diameter Cutters, Rail Cutters and Cobalt Cutters p. 40

One-Touch TCT Cutters p. 41

Accessories

p. 42-50



Lubricants p. 42

Pilot Pins, Drill Chucks and Tapping Tools p. 42-43

Arbors and Extensions p. 44-45

Power Assist p. 44

Countersinks, Drill/Taps and Chip Guard p. 45

Drilling Starter Kits p. 46

Power Worker Magnetic Stick p. 46

MOBIL CLAMP p. 47

Convert magnetic drilling machine to bench drill

Drilling Stand and Vise p. 48

Convert hand drill to drill press

Vacuum Plates p. 49

For channeled plates and smooth surfaces

Pipe Saddle Clamp System p. 50

Safe, secure drilling of pipes and tubular material

Beveling, Deburring, Faceting and Finishing Machines

p. 52-55



EKF Multi-Purpose Beveling Machine p. 52

SKF Portable Beveling Machine for Plates and Pipes p. 53

AutoCUT 500 Self-Guiding Beveling Machine p. 54

ROLEI® BE 5 Sheet Metal Deburring Machine p. 55

Custom Machines & Motors, Hand-Held Drills, Drive Units and More

p. 51, 56-67



Custom-Engineered Machines p. 51

Carbide-Tipped Hole Saws p. 56

Electric, Slow-Speed Electric Drills & Drive Units p. 57-58

Electric Drive Units/Special Motors p. 59

Pneumatic Drills & Drive Units p. 60

Corner Drills & Drive Units p. 61

Pneumatic/Hydraulic Rotary Hammers p. 62

Pneumatic Woodboring Drills p. 63

Pneumatic/Hydraulic Nut Runners p. 64

Electric/Pneumatic Dry Cutting Saws p. 65-67

Magnetic Drill Comparison Chart

PORTABLE MAGNETIC DRILLS



	MDM 40	MABasic 200	MABasic 400	MABasic 450	MABasic 850	MAB 150	MAB 455 MAB 455 SB	MAB 485 MAB 485 SB	MAB 525 MAB 525 SB
	Page 8	Page 9	Page 10	Page 10	Page 11	Page 12	Page 14	Page 16	Page 18
Annular Cutters Diameter (ø)	up to ø 1-1/2"	up to ø 1-3/8"	up to ø 1-5/8"	up to ø 1-5/8"	up to ø 3"	up to ø 1-1/2"	up to ø 2"	up to ø 2"	up to ø 2-1/2"
Twist Drills Diameter (ø)		up to ø 1/2"	up to ø 5/8"	up to ø 3/4"	up to ø 1-1/4"		up to ø 7/8"	up to ø 7/8"	up to ø 1"
Tapping Diameter (ø)								up to ø 15/16"	up to ø 15/16"
Countersinking Diameter (ø)								up to ø 1-5/8"	up to ø 2"
Reaming Diameter (ø)								up to ø 7/8"	up to ø 7/8"
Stroke	3-1/8"	6-1/3"	6-1/3"	6-1/3"	10"	1"	6-1/3"	6-1/3"	6-1/3"
Weight	24 lbs.	27 lbs.	27 lbs.	29 lbs.	53 lbs.	24 lbs.	29 lbs.	29 lbs.	35 lbs.
Speed Range 1 (RPM)	440	450	430	250	110	400	250	50-250	70-280
Speed Range 2 (RPM)			760	450	175		450	100-450	180-580
Speed Range 3 (RPM)					245				
Speed Range 4 (RPM)					385				
								✓	✓
								✓	✓
							✓	✓	✓
Electronic Safety Shutoff Sensor		✓	✓	✓			✓	✓	✓
Tool Holder	Set Screw	Set Screw	Set Screw	Set Screw	Set Screw	Set Screw	Quick-change keyless	Quick-change keyless	Quick-change keyless
Morse Taper (MT)				MT2			MT2	MT2	MT3
Safety Friction Clutch									
Torque Control									✓
Swivel/Adjustable Base							✓	✓	✓
Magnet Size	6-1/2" x 3-1/4"	6-5/8" x 3-1/3"	6-5/8" x 3-1/3"	6-5/8" x 3-1/3"	8-5/8" x 4-1/3"	6-5/16" x 3-3/16"	6-5/8" x 3-1/3"	6-5/8" x 3-1/3"	7-1/8" x 3-1/2"

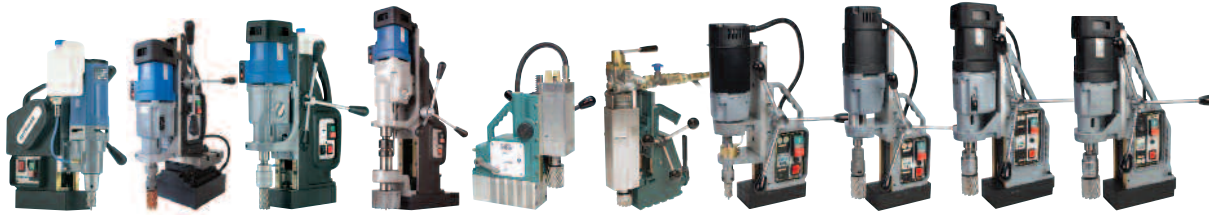

AutoMAB 1500 AutoMAB 1500 SB	MAB 825 KTS	MAB 825 MAB 825 V MAB 845	MAB 1300	AIRBOR™	HB 4400	CSU 32RL	CSU 50AC CSU 50RL	CSU 80AC	CSU 100/3RL	<i>Special Features</i>
Page 20	Page 21	Page 22	Page 24	Page 30	Page 31	Page 27	Page 28	Page 29	Page 29	
up to ø 1-1/2"	up to ø 1-5/8"	up to ø 4"	up to ø 5-1/8"	up to ø 2-1/16"	up to ø 2-1/16"	up to ø 1-1/4"	up to ø 2"	up to ø 3-3/16"	up to ø 4"	Max. hole diameter up to 5-1/8"
	up to ø 1"	up to ø 1-1/4"	up to ø 1-3/4"	up to ø 1/2"	up to ø 1/2"	up to ø 1/2"	up to ø 7/8"	up to ø 1-1/4"	up to ø 1-1/4"	Max. twist drilling up to 1-3/4"
	up to ø 1-1/8"	up to ø 1-1/8"	up to ø 1-5/8"			up to ø 3/4"	up to ø 15/16" <i>(CSU 50RL only)</i>		up to ø 1-1/8"	Max. tapping up to 1-5/8"
		up to ø 2"	up to ø 3"							
		up to ø 1-1/4"	up to ø 2"							
3"	10"	10"	3.35" (12" w/out retainer)	up to 10-1/4"	3-3/4"	5-3/4"	5-1/4"	10"	10"	
37-1/2 lbs.	99 lbs.	55 lbs.	112 lbs.	43 lbs.	48-1/2 lbs.	24 lbs.	29 lbs.	57 lbs.	57 lbs.	
360	40-110	40-110	30-80	400	0-630	450	250	100	40-140	Pneumatic Hydraulic
	65-175	65-175	50-120				450	175	120-480	
	140-360	140-360	130-350					245		
	220-600	220-600	210-550					385		
	✓	✓	✓			✓	✓ <i>(CSU 50RL only)</i>		✓	Allows thread cutting
		✓	✓			✓	✓	✓	✓	Overheating protection
		✓	✓			✓	✓	✓	✓	Magnet adhesion indicator
		✓	✓			✓	✓	✓	✓	Shuts down motor if magnetic contact lost
Set Screw		Quick-change keyless	Set Screw	Set Screw	Set Screw	Set Screw	Quick-change keyless	Quick-change keyless	Quick-change keyless	
	MT3	MT3	MT4				MT2	MT3	MT3	
		✓	✓							
✓		✓	✓			✓	✓	✓	✓	
✓	✓	✓								Swivel/adjustable base
7-1/8" x 3-1/2"	8-11/16" x 8-11/16"	8-5/8" x 4-1/3"	14" x 4-3/4"	8-3/4" x 3-1/2"	7-1/4" x 3"	6-5/16" x 3-1/4"	6-1/2" x 3-1/2"	9" x 4-3/8"	9" x 4"	



Cutter capacity
1 1/2" dia.

MDM 40

Heavy-duty compact hole drilling machine with internal cable routing

Powerful • Reliable

- 9.25 Amp double-insulated motor
- Compact, 13" high
- Lightweight, 24 lbs.
- Designed for continuous use
- Intelligent electronic torque control

Drill up to 1-1/2" dia.

- Uses annular cutters
- Integrated cutting oil reservoir
- Automatic internal lubrication

Special Feature

- Internal cable routing protects the motor power cord from external damage

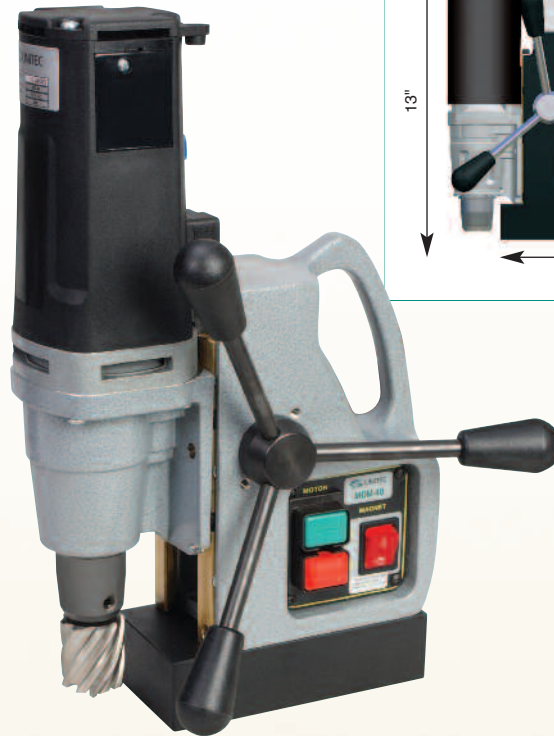

Model MDM 40



All CS Unitec high-density dual-coil magnets are ground, not cast, and are wound into two circles to increase the surface area and density of the magnetic field.



Model MDM 40 Specifications

Motor Power	9.25 Amp / 110 Volt
Weight	24 lbs.
Hole Capacity	1 1/2" dia.
Speed	440 RPM
Magnet Base Size	6 1/2" L x 3 1/4" W
Dimensions	13" H x 9 1/2" L x 7" W
Magnetic Force (1" plate)	2640 lbs.
Arbor Bore	3/4" Weldon Shank
Automatic Lubrication	Included

* 220 Volt / 50 Hz also available

Cutter Capacity	Stroke (length)	Speed Range (RPM)
 ø 1 1/2"	 3 1/8"	 440

Standard Equipment

- 1 Magnetic drilling machine
- 1 Pilot pin
- 1 Safety chain
- 1 Hexagon socket screw key SW 4

Standard Equipment

also includes auto lubrication, safety strap, carabin hook, allen keys, steel shipping case†, operating manual and warranty certificate.

† Steel case intended mainly for shipping purposes; damage may occur in transit.

➤ *Annular Cutters: pages 32-41* ➤ *Accessories: pages 42-50*

MABasic 200



Heavy-duty, purpose-built, single-speed workhorse

Powerful • Reliable

- Strong 8.2 Amp motor
- Compact, lightweight and portable – 14-1/4" high, 27 lbs.

Drill up to 1-3/8" dia.

- Uses annular cutters; 6-1/3" stroke
- Twist drilling up to 1/2" dia.; 3-1/3" stroke with included geared chuck
- Internal lubrication system



With included 1/2" chuck (Part No. IBC 18), this model easily converts to a standard drill press with a 3 1/3" stroke for conventional twist drills.



Standard Equipment includes lubrication bottle, 3/4" weldon shank, 1/2" geared chuck, safety strap, carabin hook, allen keys, pilot pin and carrying case.

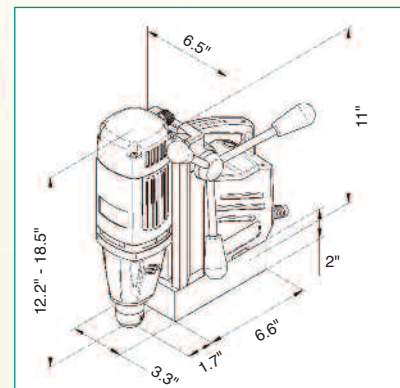

Equipped with Electronic Safety Shutoff Sensor (see p. 3)

MABasic 200 Specifications

Motor Power	8.2 Amp / 110 Volt
Weight	27 lbs.
Hole Capacity	1 3/8" dia.
Twist Drill Capacity	1/2" dia.
Speed	450 RPM
Magnet Base Size	6 5/8" W x 3 1/3" H
Dimensions	14 1/4" H x 9 1/2" L x 4 3/8" W
Magnetic Force (1" plate)	3080 lbs.
Arbor Bore	3/4" Weldon Shank
Internal Lubrication	Oil Pump Bottle Included

➤ *Annular Cutters: pages 32-41* ➤ *Accessories: pages 42-50*



MABasic 400 & MABasic 450



Professional-grade, two-speed versatility – powerful and reliable



MABasic 400
Drill up to 1-5/8" dia.

- 9.5 Amp double-insulated motor
- 3/4" direct arbor
- Uses annular cutters
- Twist drilling up to 3/4" dia.; 3-1/3" stroke with chuck
- Internal lubrication system
- Compact and lightweight

Equipped with Electronic Safety Shutoff Sensor (see p. 3)

With included 1/2" geared chuck (Part No. IBC 18), the MABasic 400 easily converts to standard drill press with a 3 1/3" stroke for conventional twist drills.



MABasic 450
Drill up to 1-5/8" dia.

- 10.5 Amp double-insulated motor
- MT2 – 3/4" direct arbor with automatic cooling
- Uses annular cutters
- Twist drilling up to 3/4" dia.; 6-1/3" stroke with chuck
- Internal lubrication system
- Compact and lightweight

With included 3/4" geared chuck (Part No. IBC 22), the MABasic 450 easily converts to standard drill press with a 6 1/3" stroke for conventional twist drills.

Specifications	MABasic 400	MABasic 450
Motor Power	9.5 Amp / 110 Volt*	10.5 Amp / 110 Volt*
Weight	27 lbs.	29 lbs.
Hole Capacity	1 5/8" dia.	1 5/8" dia.
Twist Drill Capacity	5/8" dia.	3/4" dia.
Speeds	430 / 760 RPM (2 gears)	250 / 450 RPM (2 gears)
Magnet Base Size	6 5/8" W x 3 1/3" H	6 5/8" W x 3 1/3" H
Dimensions	14 1/4" H x 9 1/2" L x 4 3/8" W	14 1/4" H x 9 1/2" L x 4 3/8" W
Magnetic Force (1" plate)	3080 lbs.	3080 lbs.
Arbor Bore	3/4" Weldon Shank	3/4" Weldon Shank
Spindle	N/A	MT2
Internal Lubrication	Oil Pump Bottle Included	Oil Pump Bottle Included

* 220 Volt / 50 Hz also available

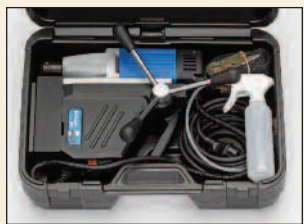

Standard Equipment includes lubrication bottle, geared chuck, safety strap, carabin hook, allen keys, pilot pin and carrying case.

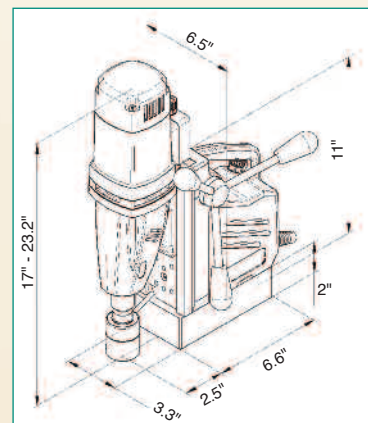
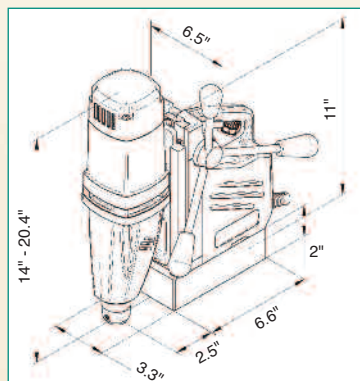

► **Annular Cutters:** pages 32-41 ► **Accessories:** pages 42-50

MABasic 850



4-gear, powerful motor for demanding jobs

Powerful • Reliable

- 16 Amp double-insulated motor
- MT3 – 3/4" direct arbor with automatic cooling
- 19-3/8" high, 53 lbs.
- High-speed, 4-speed gearbox

Drill up to 3" dia.

- Uses annular cutters; 10" stroke
- Twist drilling up to 1-1/4" dia. with included chuck
- Internal lubrication system



With included 3/4" chuck (Part No. IBC 21), or MT3, this model easily converts to a standard drill press for conventional twist drills.

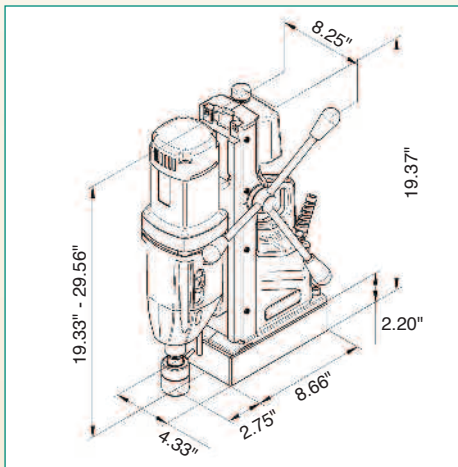

Standard Equipment includes geared chuck, safety strap, carabin hook, allen keys, pilot pin and carrying case.

MABasic 850 Specifications

Motor Power	16 Amp / 110 Volt
Weight	53 lbs.
Hole Capacity	3" dia.
Twist Drill Capacity	1 1/4" dia.
Speeds	1: 110 RPM, 2: 175 RPM 3: 245 RPM, 4: 385 RPM
Magnet Base Size	4 1/3" W x 8 5/8" L
Dimensions	19 3/8" H x 11 5/8" L x 8 1/4" W
Magnetic Force (1" plate)	6000 lbs.
Arbor Bore	3/4" Weldon Shank
Spindle	MT3
Internal Lubrication	Included

* 220 Volt / 50 Hz also available

➤ [Annular Cutters: pages 32-41](#) ➤ [Accessories: pages 42-50](#)



Cutter capacity
1 1/2" dia.

MAB 150

Horizontal motor mount for drilling in tight spaces

Powerful • Reliable

- 9.25 Amp double-insulated motor
- Ultra compact, 7" high
- Lightweight, 24 lbs.
- Designed for continuous use
- Intelligent electronic torque control

Drill up to 1-1/2" dia.*

- Uses annular cutters
- Integrated cutting oil reservoir
- Automatic internal lubrication

Integrated Safety

- Internal cable routing
- Simple, ergonomic arrangement of controls for one-handed operation

Internal cable routing protects the motor power cord from external damage

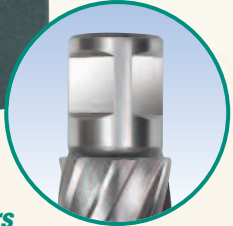
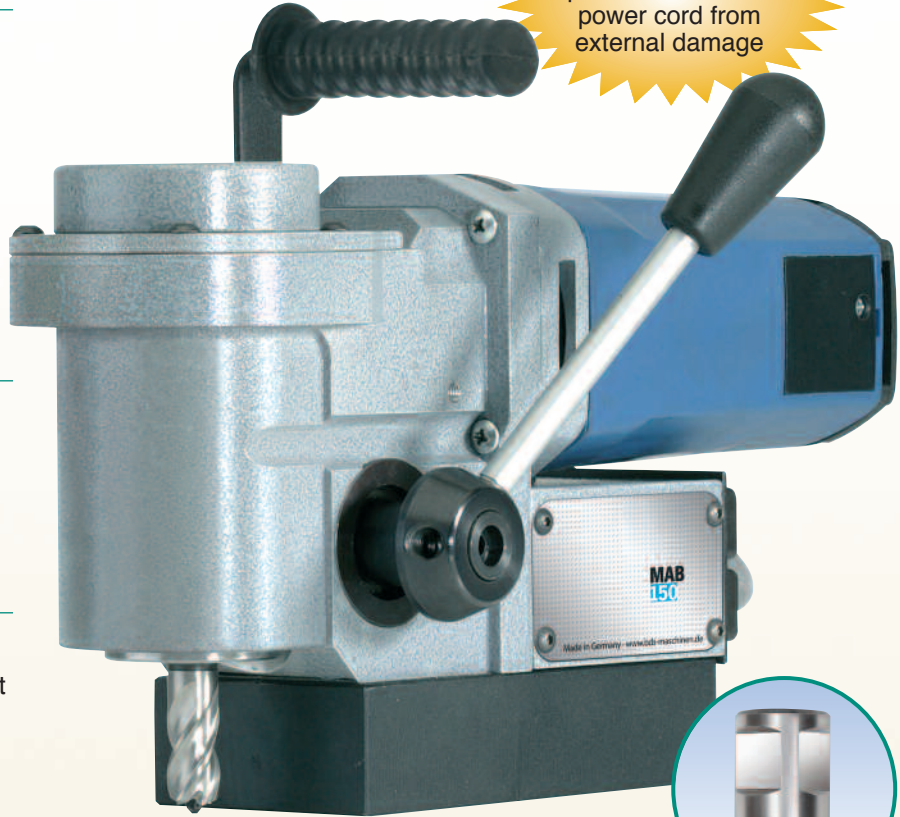

MAB 150 uses standard 3/4" shank annular cutters



Automatic internal lubrication with pressure pump bottle

* Model MAB 150 accepts cutters with a 3/4" weldon shank and a maximum depth of cut of 1".

Optional ratchet-style advancing mechanism for work in spaces with limited clearance. (14mm square drive)

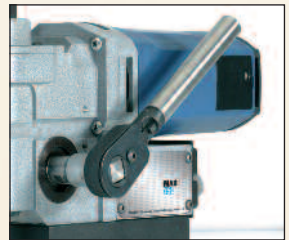

Cutter Capacity



ø 1 1/2"

Stroke (length)



1"

Speed Range (RPM)



400



Switches for power and magnet adhesion are arranged for simple, uncomplicated operation.

► Annular Cutters: pages 32-41 ► Accessories: pages 42-50

MAB 150 Specifications

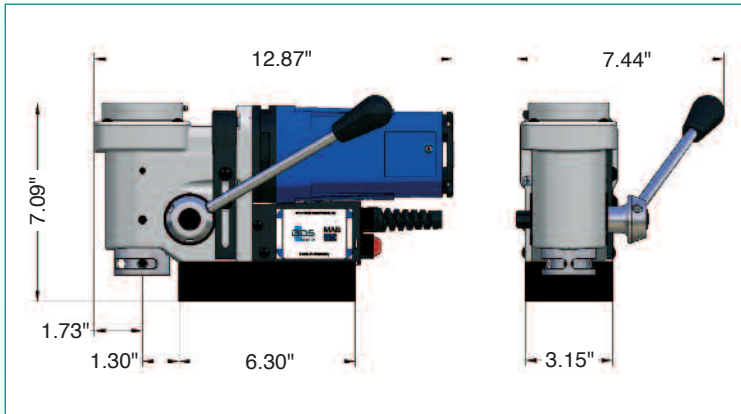

Model MAB 150

Model MAB 150 Specifications

Motor Power	9.25 Amp / 110 Volt
Weight	24 lbs.
Hole Capacity	1 1/2" dia.
Speed	400 RPM
Magnet Base Size	6 5/16" L x 3 3/16" W
Dimensions	7" H x 12 7/8" L x 7 1/2" W
Magnetic Force (1" plate)	2640 lbs.
Arbor Bore	3/4" Weldon Shank
Automatic Lubrication	Included

* 220 Volt / 50 Hz also available

Standard Equipment

- 1 Magnetic drilling machine
- 1 Pilot pin
- 1 Steel shipping case[†]
- 1 Safety chain
- 1 Hexagon socket screw key SW 4
- 1 Operating manual
- 1 Warranty certificate



Standard Equipment also includes auto lubrication, safety strap, carabin hook and allen keys.

[†] Steel case intended mainly for shipping purposes; damage may occur in transit.

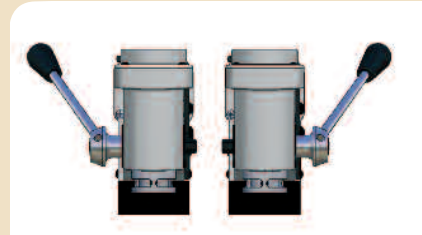

Advancing lever can be mounted on either the left or right side of the MAB 150.

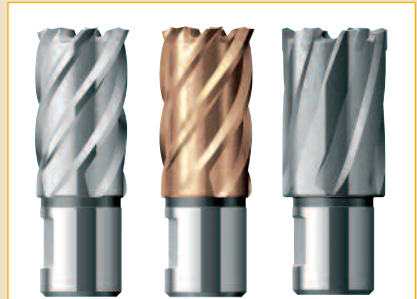

Model MAB 150 accepts cutters with 3/4" weldon shank. This unit has a maximum depth of cut of 1".

See pages 32-41 for our HSS, TiAlN and Carbide-tipped cutters.



➤ [Annular Cutters: pages 32-41](#) ➤ [Accessories: pages 42-50](#)



MAB 455 & MAB 455 SB



High power with keyless quick-change chuck system

Powerful • Reliable

- 10.5 Amp double-insulated motor
- 17-1/4" high, 29 lbs.
- High-speed, 2-speed oilbath gearbox, ideal for annular cutters and twist drills
- Designed for continuous use
- Intelligent electronic torque control

Drill up to 2" dia.

- Uses annular cutters
- Twist drilling up to 7/8" (with included chuck IBC 22)
- Integrated cutting oil reservoir
- Automatic internal lubrication
- Swivel base (model MAB 455 SB) has max. capacity of 1-3/4" dia.

Keyless Cutter Mount

- Quick-change keyless cutter system for 3/4" Weldon shank, standard
- Also includes manual arbor for 3/4" Weldon shank (MT2) with set screws

Integrated Safety

- Green/Red LED magnetic force indicator for safe operation
- Internal cable routing
- Simple, ergonomic arrangement of controls for one-handed operation
- Emergency-off function



Internal cable routing protects the motor power cord from external damage



With included 3/4" chuck (Part No. IBC 22), or MT2, this model easily converts to a standard drill press with a 5" stroke for conventional twist drills.



MAB 455
For swivel base, order **MAB 455 SB**

Model MAB 455 SB features a swivel base providing 20° movement left and right and 5/8" forward and backward.

Cutter Capacity	Twist Drill / Countersink	Stroke (length)	Two-Speed (RPM)	Magnet Force Indicator
 MAB 455: ø 2" MAB 455 SB: ø 1 3/4"	 ø 7/8"	 6 1/3"	 250 / 450	 SafeMag™

Equipped with Electronic Safety Shutoff Sensor (see p. 3)

► *Annular Cutters: pages 32-41* ► *Accessories: pages 42-50*

MAB 455 & MAB 455 SB Specifications

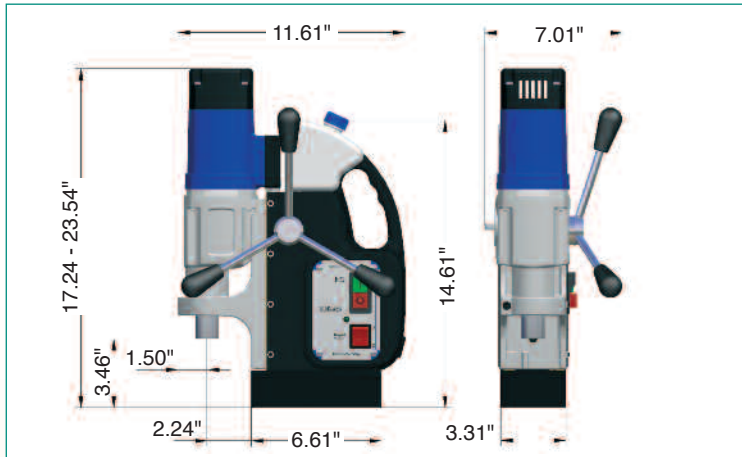

Model MAB 455 & MAB 455 SB

Model MAB 455 & 455 SB Specifications

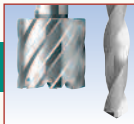

Motor Power	10.5 Amp / 110 Volt
Weight	29 lbs.
Hole Capacity MAB 455	2" dia.
Hole Capacity MAB 455 SB	1 ³ / ₄ " dia.
Twist Drill Capacity	7/8" dia.
Speeds	250 / 450 RPM (2 gears)
Magnet Base Size	3 ¹ / ₃ " W x 6 ⁵ / ₈ " L
Dimensions	17 ¹ / ₄ " H x 11 ⁵ / ₈ " L x 7" W
Magnetic Force (1" plate)	3750 lbs.
Arbor Bore	3/4" Weldon Shank
Spindle	MT2
Automatic Lubrication	Included
Swivel Base	Order MAB 455 SB

* 220 Volt / 50 Hz also available

Standard Equipment

- 1 Magnetic drilling machine
- 1 Quick-change arbor system
KEYLESS Weldon 3/4"
- 1 Manual arbor with set screws,
Weldon 3/4", MT2
- 1 3/4" geared chuck, MT2
- 2 Pilot pins - 1" and 2" depth
- 1 Safety chain
- 1 Drift key MT2
- 1 Warranty certificate



Standard Equipment
also includes
molded plastic
carrying case,
operating
manual, auto
lubrication,
safety strap,
carabin hook
and allen keys.

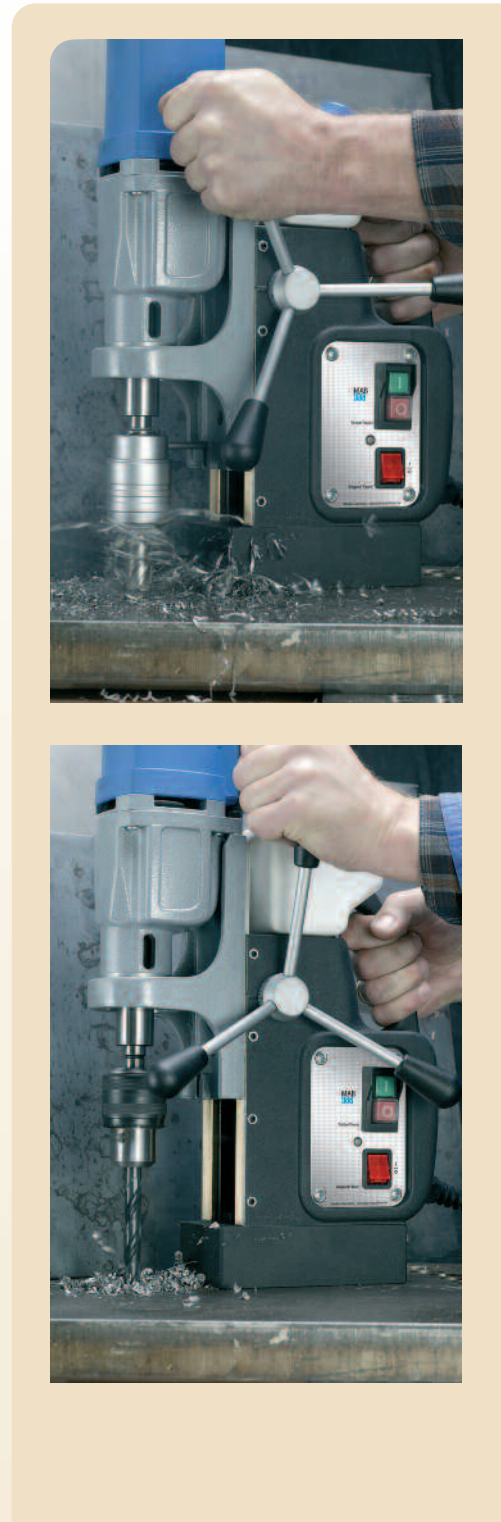

PORTABLE MAGNETIC DRILLS

➤ [Annular Cutters: pages 32-41](#) ➤ [Accessories: pages 42-50](#)



Cutter capacity
2" dia.

MAB 485 & MAB 485 SB



Versatile for workshop and assembly applications

Powerful • Reliable

- 10.5 Amp double-insulated motor
- 17-1/4" high, 29 lbs.
- High-speed, variable-speed oilbath gearbox, ideal for annular cutters and twist drills
- Designed for continuous use
- Intelligent electronic torque control

Drill up to 2" dia. Tap up to 15/16" dia.

- Uses annular cutters
- Twist drilling up to 7/8" dia. (with included chuck IBC 22)
- Tapping capacity 3/16" to 15/16" dia.
- Integrated cutting oil reservoir
- Automatic internal lubrication
- Swivel base (model MAB 485 SB)

Keyless Cutter Mount

- Quick-change keyless cutter system for 3/4" Weldon shank, standard
- Also includes manual arbor for 3/4" Weldon shank (MT2) with set screws



Included Geared Chuck

With a 3/4" chuck (Part No. IBC 22), or MT2, this model easily converts to a standard drill press with a 5" stroke for conventional twist drills.

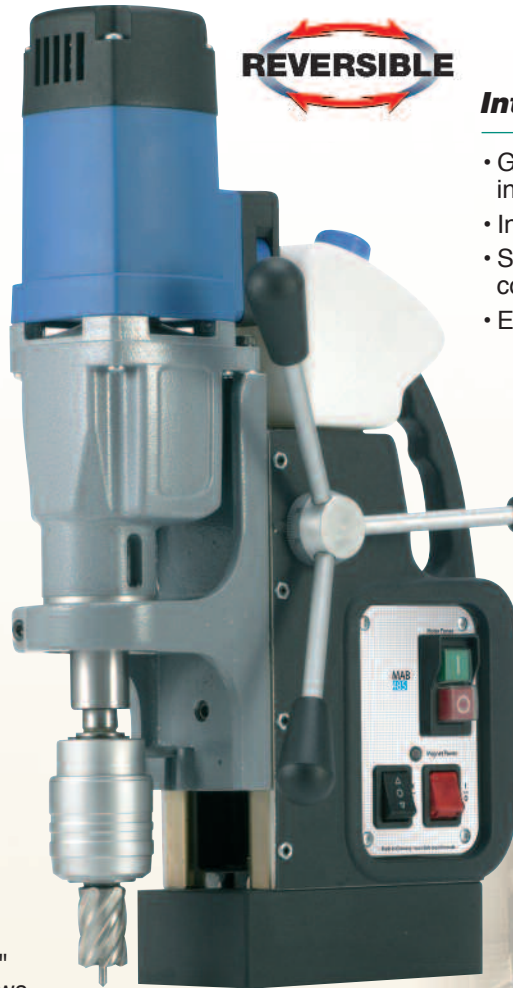

Integrated Safety

- Green/Red LED magnetic force indicator for safe operation
- Internal cable routing
- Simple, ergonomic arrangement of controls for one-handed operation
- Emergency-off function

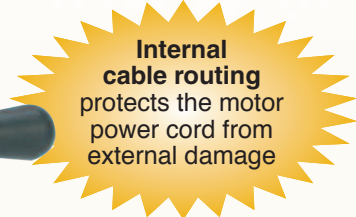

Equipped with Electronic Safety Shutoff Sensor (see p. 3)



Model MAB 485 SB features a swivel base providing 20° movement left and right and 5/8" forward and backward.

Cutter Capacity	Twist Drill / Countersink	Ream / Tap	Stroke (length)	2-gear Variable Speed (RPM)	Electronics	Overheat Protection	Magnet Force Indicator	Reversible (CW/CCW)
$\varnothing 2$	$\varnothing 7/8" / \varnothing 15/8$	$\varnothing 7/8" / \varnothing 15/16"$	6 1/3"	50-250 / 100-450	Variable-speed Control	CoolMag™	SafeMag™	

► Annular Cutters: pages 32-41 ► Accessories: pages 42-50

MAB 485 & MAB 485 SB Specifications

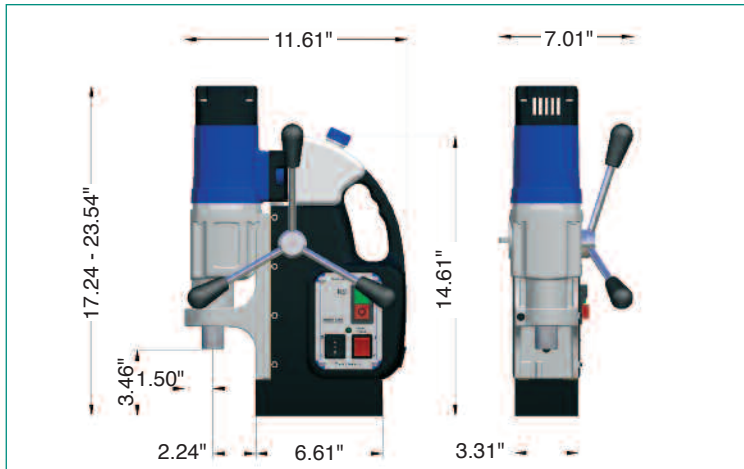

Model MAB 485 & MAB 485 SB

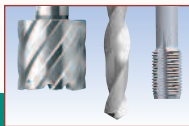

Model MAB 485 Specifications

Motor Power	10.5 Amp / 110 Volt
Weight	29 lbs.
Hole Capacity	2" dia.
Twist Drill Capacity	7/8" dia.
Tapping Capacity	15/16" dia.
Speeds	50-250 and 100-450 RPM
Magnet Base Size	3 1/3" W x 6 5/8" L
Dimensions	17 1/4" H x 11 5/8" L x 7" W
Magnetic Force (1" plate)	3750 lbs.
Arbor Bore	3/4" Weldon Shank
Spindle	MT2
Automatic Lubrication	Included
Swivel Base	Order MAB 485 SB

* 220 Volt / 50 Hz also available

Standard Equipment

- 1 Magnetic drilling machine
- 1 Quick-change arbor system
KEYLESS Weldon 3/4"
- 1 Manual arbor with set screws,
Weldon 3/4", MT2
- 1 3/4" geared drill chuck, MT2
- 2 Pilot pins - 1" and 2" depth
- 1 Safety chain
- 1 Drift key MT2
- Tap collet adapters - 3/8", 1/2" and 3/4"
- 1 Warranty certificate

Standard Equipment
also includes
molded plastic
carrying case,
operating
manual, auto
lubrication,
safety strap,
carabin hook
and allen keys.



Shown with optional Pipe Saddle Clamp System for safe, secure drilling of pipes and tubular material. See page 50 for details.

PORTABLE MAGNETIC DRILLS

➤ Annular Cutters: pages 32-41 ➤ Accessories: pages 42-50



Cutter capacity
2 1/2" dia.

MAB 525 & MAB 525 SB

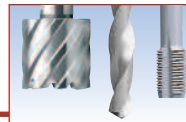

High power, ideal for production use

Powerful • Reliable

- 14.5 Amp double-insulated motor
- 19" high, 35 lbs.
- High-speed, 2-speed oilbath gearbox, ideal for annular cutters and twist drills
- Designed for continuous use
- Intelligent electronic torque control

Drill up to 2-1/2" dia. Tap up to 15/16" dia.

- Uses annular cutters
- Twist drilling up to 1" (with included chuck IBC 21)
- Tapping capacity 15/16"
- Integrated cutting oil reservoir
- Automatic internal lubrication
- Swivel base (model MAB 525 SB)

Keyless Cutter Mount

- Quick-change keyless cutter system for 3/4" Weldon shank
- Also includes manual arbor for 3/4" Weldon shank (MT3) with set screws

Integrated Safety

- Green/Red LED magnetic force indicator for safe operation
- Internal cable routing
- Simple, ergonomic arrangement of controls for one-handed operation
- Emergency-off function

Model MAB 525 SB features a swivel base providing 20° movement left and right and 5/8" forward and backward.

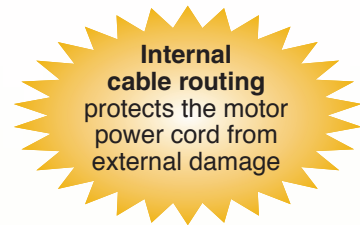









Internal cable routing protects the motor power cord from external damage

Equipped with Electronic Safety Shutoff Sensor (see p. 3)

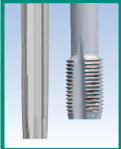

With included 3/4" chuck (Part No. IBC 21), or MT3, this model easily converts to a standard drill press with a 5" stroke for conventional twist drills.

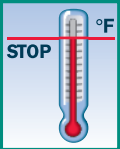

Cutter Capacity	Twist Drill / Countersink	Ream / Tap	Stroke (length)	2-gear Variable Speed (RPM)	Electronics	Overheat Protection	Magnet Force Indicator	Reversible (CW/CCW)
								
ø 2 1/2"	ø 1" / ø 2"	ø 7/8" / ø 15/16"	6 1/3"	70-280 180-580	Variable-speed Control	CoolMag™	SafeMag™	

► Annular Cutters: pages 32-41 ► Accessories: pages 42-50

MAB 525 & MAB 525 SB Specifications

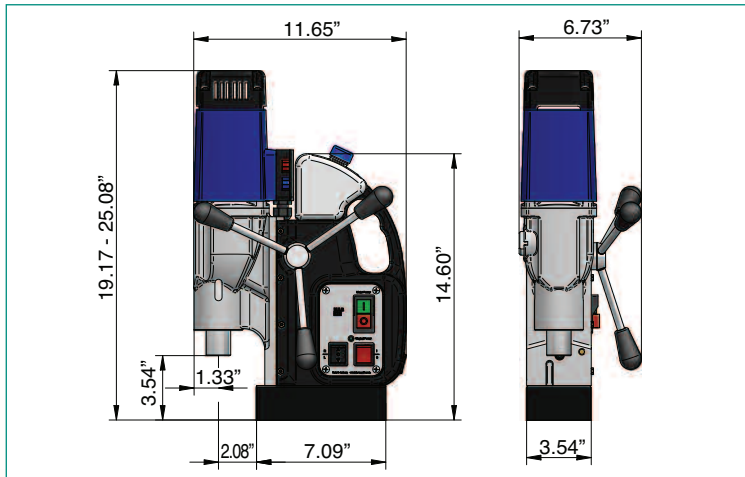

Model MAB 525 & MAB 525 SB

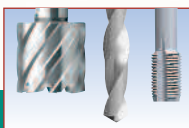

Model MAB 525 Specifications

Motor Power	14.5 Amp / 110 Volt
Weight	35 lbs.
Hole Capacity	2 1/2" dia.
Twist Drill Capacity	1" dia.
Tapping Capacity	15/16" dia.
Speeds	70-280 and 180-580 RPM
Magnet Base Size	3 1/2" W x 7 1/8" L
Dimensions	19" H x 11 3/4" L x 6 3/4" W
Magnetic Force (1" plate)	4500 lbs.
Arbor Bore	3/4" Weldon Shank
Spindle	MT3
Automatic Lubrication	Included
Swivel Base	Order MAB 525 SB

* 220 Volt / 50 Hz also available

Standard Equipment

- 1 Magnetic drilling machine
- 1 Quick-change arbor system
KEYLESS Weldon 3/4"
- 1 Manual arbor with set screws,
Weldon 3/4", MT3
- 1 3/4" geared drill chuck with MT3
- 2 Pilot pins - 1" and 2" depth
- 1 Safety chain
- 1 Drift key MT3
- Tap collet adapters - 1/4", 3/8",
1/2" and 3/4"
- 1 Warranty certificate

Standard Equipment
also includes
molded plastic
carrying case,
operating
manual, auto
lubrication,
safety strap,
carabin hook
and allen keys.

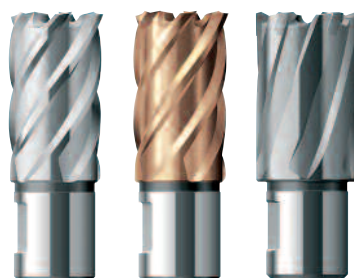

See pages 32-41 for our HSS, TiAlN
and Carbide-tipped cutters.



➤ [Annular Cutters: pages 32-41](#) ➤ [Accessories: pages 42-50](#)



Cutter capacity
1 1/2" dia.

AutoMAB 1500 & 1500 SB



Heavy-duty compact drill with automatic feed

Powerful • Reliable

- 10.5 Amp double-insulated motor
- Compact, lightweight and portable: 16-1/8" high, 37-1/2 lbs.
- Power feed automatically controls drill pressure to maintain optimal RPM and feed rate
- Designed for continuous use
- Ideal hole cutting machine for steel fabricators, contractors and plant maintenance professionals

Drill up to 1-1/2" dia.

- Uses annular cutters
- Automatic feed mechanism with automatic stop and manual retraction
- Integrated cutting oil reservoir
- Automatic internal lubrication
- Swivel base 30° left and right (model AutoMAB 1500 SB)

Integrated Safety

- Internal cable routing
- Simple, ergonomic arrangement of controls for one-handed operation
- Emergency-off function

Standard Equipment

- 1 Magnetic drilling machine
- 1 Steel carrying case†
- 1 Safety chain
- 1 Operating manual
- 1 Warranty certificate

Standard Equipment

also includes auto lubrication, safety strap, carabin hook and allen keys.

† Steel case intended mainly for shipping purposes; damage may occur in transit.

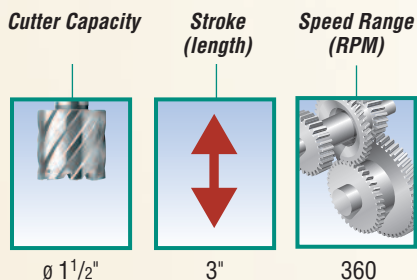

Automatic Feed is ideal for production applications, as well as steel fabricators, contractors and plant maintenance professionals.



Model AutoMAB 1500 SB features a swivel base providing 30° movement left and right.

Model AutoMAB 1500 Specifications

Motor Power	10.5 Amp / 110 Volt
Weight	37 1/2 lbs.
Hole Capacity	1 1/2" dia.
Speed	360 RPM
Magnet Base Size	3 1/2" W x 7 1/8" L
Dimensions	16 1/8" H x 11" L x 7 13/16" W
Magnetic Force (1" plate)	2640 lbs.
Arbor Bore	3/4" Weldon Shank
Automatic Lubrication	Included
Swivel Base	Order AutoMAB 1500 SB

* 220 Volt / 50 Hz also available

► **Annular Cutters:** pages 32-41 ► **Accessories:** pages 42-50

MAB 825 KTS



Versatile machine with adjustable X and Y positioning

Powerful • Reliable

- 16 Amp double-insulated motor
- 4-speed oilbath gearbox for applications requiring high power
- Designed for continuous use
- Infinitely variable torque control and full-wave control electronics
- Ideal for a wide variety of drilling, boring and slotting applications
- Includes servo-assisted drilling feature to help maintain feed pressure during operation

Drill up to 1-5/8" dia. Tap up to 1-1/8" dia.

- Multi-axis positioning
- Uses annular cutters
- 10" stroke
- Twist drilling 1" dia., with included geared chuck IBC 21
- Tapping to 1-1/8"
- Integrated cutting oil reservoir
- Automatic internal lubrication

Integrated Safety

- Simple, ergonomic arrangement of controls for one-handed operation
- Emergency-off function

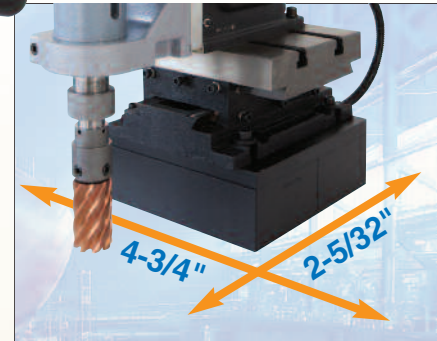
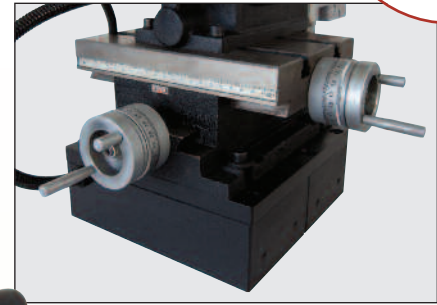

Model MAB 825 KTS features multi-axis positioning, allowing the drill to be adjusted up to 2-5/32" forward/backward and up to 4-3/4" left/right after magnet is adhered to surface. Ideal for job site drilling, boring and slotting applications where dismantling is not feasible.

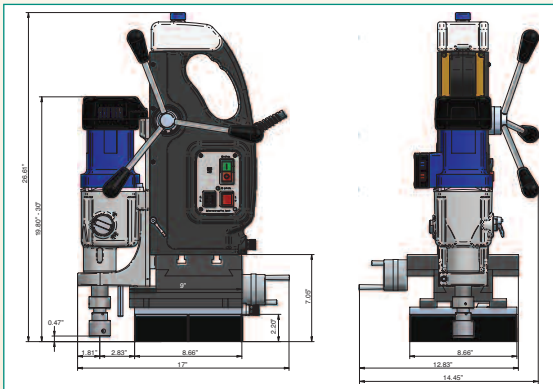

Model MAB 825 KTS Specifications

Motor Power	16 Amp / 110 Volt
Weight	99 lbs.
Hole Capacity	1 5/8" dia.
Twist Drill Capacity	1" dia.
Tapping Capacity	1 1/8" dia.
Speeds	40-110, 65-175 140-360, 220-600 RPM
Magnet Base Size	8 11/16" W x 8 11/16" L
Dimensions	18 5/8" H x 14 7/16" L x 9 7/16" W
Magnetic Force (1" plate)	6600 lbs.
Arbor Bore	3/4" and 1 1/4", standard
Spindle	MT3
Automatic Lubrication	Included

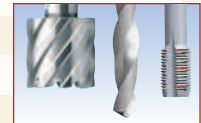

Standard Equipment

- 1 Magnetic drilling machine
- 1 Steel carrying case[†]
- 1 3/4" geared chuck
- 1 Safety chain
- 1 Operating manual
- 1 Warranty certificate

Standard Equipment
also includes auto lubrication, safety strap, carabin hook and allen keys.

[†] Steel case intended mainly for shipping purposes; damage may occur in transit.

* 220 Volt / 50 Hz also available

➤ [Annular Cutters: pages 32-41](#) ➤ [Accessories: pages 42-50](#)



Cutter capacity
4" dia.

MAB 825 & MAB 845

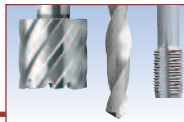

Ideal for steel engineering, plant construction and more

Powerful • Reliable

- 16 Amp double-insulated motor
- 4-speed oilbath gearbox for applications requiring high power
- Designed for continuous use
- Infinitely variable torque control and full-wave control electronics

Drill up to 4" dia. Tap up to 1-1/8" dia.

- Uses annular cutters
- Twist drilling and reaming up to 1-1/4" dia. with included geared chuck IBC 21
- Tapping up to 1-1/8"
- Integrated cutting oil reservoir
- Automatic internal lubrication
- Automatic feed (model MAB 825 V), ideal for production applications
- Swivel base (model MAB 845)

Keyless Cutter Mount

- Quick-change keyless cutter system for 3/4" Weldon shank
- Arbor for 1-1/4" Weldon shank
- Also includes manual arbor for 3/4" Weldon shank (MT3) with set screws

Integrated Safety

- Green/Red LED magnetic force indicator for safe operation
- Internal cable routing
- Simple, ergonomic arrangement of controls for one-handed operation
- Emergency-off function



Internal cable routing protects the motor power cord from external damage

Equipped with Electronic Safety Shutoff Sensor (see p. 3)



4 Gears with Variable Speed



Twist Drilling



Tapping



Reaming



Countersinking

MAB 825

Standard model with 16 Amp motor







MAB 825 V

Includes automatic feed - ideal for production applications

MAB 845

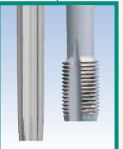
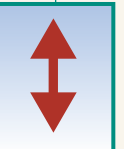
Includes 30° movement left and right and 3/4" forward and backward

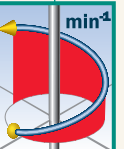
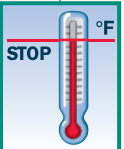
See pages 26 and 43 for Tap Holders and Accessories

Cutter Capacity	Twist Drill / Countersink	Ream / Tap	Stroke (length)	4-gear Variable Speed (RPM)	Electronics	Overheat Protection	Magnet Force Indicator	Reversible (CW/CCW)
								
ø 4"	ø 1 1/4" / ø 2"	ø 1 1/4" / ø 1 1/8"	10"	40-110 65-175 140-360 220-600	Variable-speed Control	CoolMag™	SafeMag™	

MAB 825 & MAB 845 Specifications



Cutter capacity
4" dia.

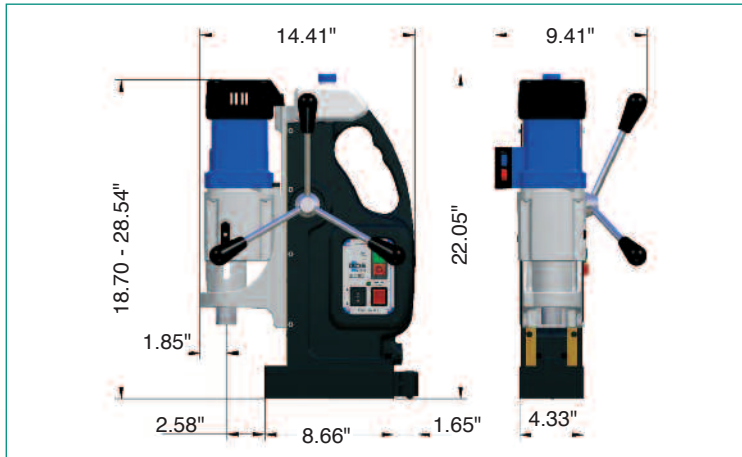

Model MAB 825, 825 V & 845

Model MAB 825 & 845 Specifications

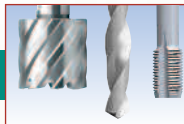

Motor Power	16 Amp / 110 Volt
Weight	55 lbs.
Hole Capacity	4" dia.
Twist Drill Capacity	1 1/4" dia.
Tapping Capacity	1 1/8" dia.
Speeds	40-110, 65-175 140-360, 220-600 RPM
Magnet Base Size	4 1/3" W x 8 5/8" L
Dimensions	18 5/8" H x 14 7/16" L x 9 7/16" W
Magnetic Force (1" plate)	6600 lbs.
Arbor Bore	3/4" and 1 1/4", standard
Spindle	MT3
Automatic Lubrication	Included
Automatic Feed	Order MAB 825 V
Swivel Base	Order MAB 845

* 220 Volt / 50 Hz also available

Standard Equipment

- 1 Magnetic drilling machine
- 1 Quick-change arbor system
KEYLESS Weldon 3/4"
- 1 Manual arbor with set screws,
Weldon 3/4", MT3
- 1 Arbor 1 1/4" Weldon, MT3*
- 1 3/4" geared chuck
- 4 Pilot pins - 1", 2", 3" and 4" depth
- 1 Safety chain
- 1 Hexagon socket screw key SW 6
- 1 Drift key MT3
- 1 Warranty certificate
- 1 Carrying case**

* Optional accessory for MAB 825 V

** Not available for MAB 825 V

Standard Equipment
also includes
operating
manual, auto
lubrication,
safety strap,
carabin hook
and allen keys.

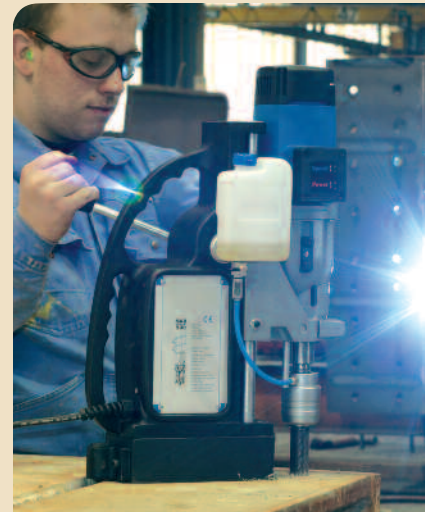

Model MAB 845 features a swivel base providing 30° movement left and right and 3/4" forward and backward.

Rolling Transport Case

Optional robust transport case with wheels, carrying handle and sturdy closures. Protect your MAB 825/845 from water and dust with this rugged case.

Order No. ZHK 825



➤ [Annular Cutters: pages 32-41](#) ➤ [Accessories: pages 42-50](#)



Cutter capacity
5 1/8" dia.

MAB 1300

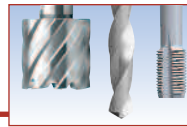

Large holes – up to 5 1/8" diameter Tapping up to 1 5/8" diameter

Powerful • Reliable

- 20 Amp double-insulated motor
- 34-1/2" high, 112 lbs.
- 4-speed oilbath gearbox for applications requiring high power
- Designed for continuous use
- Infinitely variable torque control and full-wave control electronics

Drill up to 5-1/8" dia. Tap up to 1-5/8" dia.

- Uses annular cutters 7/16" to 5-1/8" dia., 1" and 2" depth 13/16" to 4-3/4" dia. for 4-1/4" depth*
- Twist drilling up to 1-3/4" - uses MT4, countersinking up to 3" dia.
- Tapping up to 1-5/8"
- Reaming up to 2"
- Automatic internal lubrication

Integrated Safety

- Green/Red LED magnetic force indicator for safe operation
- Equipped with Electronic Safety Shutoff Sensor (see p. 3)
- Emergency-off function

*Ideal for use with
TCT Carbide cutters
up to 5 1/8" dia. –
see pages 38-39.*



* 4" depth cutters or longer require purchase of ZIA 419M adapter and 1-1/4" Weldon adapter.



Equipped with
Electronic Safety
Shutoff Sensor (see p. 3)



4 Gears
with Variable
Speed



Twist Drilling



Tapping







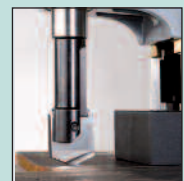

Reaming

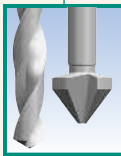
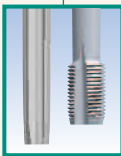

Countersinking

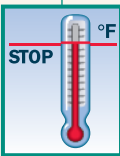

Optional
Special-Purpose
Cutting Tool

Cutter Capacity	Twist Drill / Countersink	Ream / Tap	Stroke (length)	4-gear Variable Speed (RPM)	Electronics	Overheat Protection	Magnet Force Indicator	Reversible (CW/CCW)
 ø 5-1/8"	 ø 1-3/4" / ø 3"	 ø 2" / ø 1-5/8"	 3.35" (12" without retainer)	 30-80 50-120 130-350 210-550	 Variable-speed Control	 CoolMag™	 SafeMag™	

MAB 1300 Specifications



Cutter capacity
5 1/8" dia.

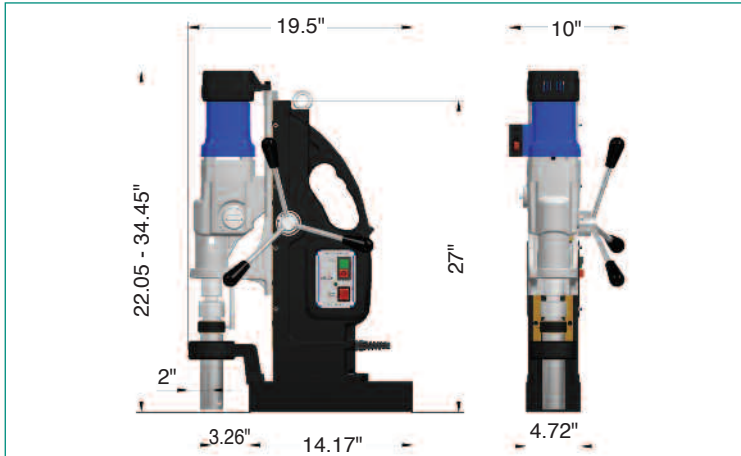

Model MAB 1300

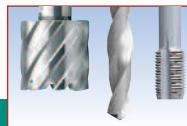

Model MAB 1300 Specifications

Motor Power	20 Amp / 110 Volt
Weight	112 lbs.
Hole Capacity	5 1/8" dia.**
Twist Drill Capacity	1 3/4" dia.
Tapping Capacity	1 5/8" dia.
Speeds	30-80, 50-120 130-350, 210-550 RPM
Magnet Base Size	4 3/4" W x 14" L
Dimensions	34 1/2" H x 19 1/2" L x 10" W
Magnetic Force (1" plate)	23,600 lbs.
Arbor Bore	1 1/4" (3/4" adapter included)
Spindle	MT4
Automatic Lubrication	Included

* 220 Volt / 50 Hz also available

** Maximum hole diameter is with TCT Carbide cutters - see p. 38-39.

Standard Equipment

- 1 Magnetic drilling machine
- 1 Carrying case on wheels
- 1 Arbor adapter to 3/4" Weldon
- 1 Safety chain
- 1 Hexagon socket screw key SW6
- 1 Drift key MT4
- 1 Operating manual
- 1 Warranty certificate



Standard Equipment
also includes
auto lubrication,
safety strap,
carabin hook
and allen keys.

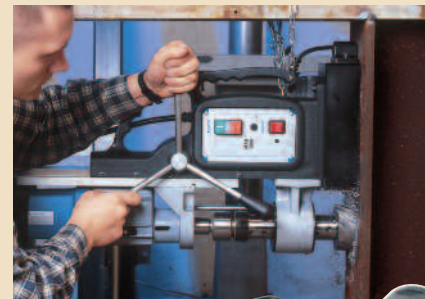

Accessories

See page 26
for tapping
accessories
and wheeled
carrying case.



ZHK 1300
wheeled
carrying case
included with
MAB 1300

PORTABLE MAGNETIC DRILLS

➤ Annular Cutters: pages 32-41 ➤ Accessories: pages 42-50

MAB 1300 Accessories



Cutter capacity
5 1/8" dia.



Rolling Transport Case for MAB 1300



Order No. **ZHK 1300**

Robust transport case with wheels, carrying handle and sturdy closures. Protect your investment from water and dust with this rugged case. Four large ABS locks and an interior configuration customized for machine to secure drill and accessories during transit. Lightweight, heavy-duty plastic construction and robust ABS wheels.

Drill not included with ZHK 1300. Purchase of MAB 1300 drill includes ZHK 1300 case. See page 23 for MAB 825/845 case.



Watertight, shock-proof and robust – the right protection for your machine.

Four large ABS locks secure the robust plastic case

Tapping Accessories for MAB 1300, MAB 825, MAB 845 and CSU 100/3RL

Heavy-duty Tap Holders

- Positive, accurate driving of larger-sized taps
- No slippage or tap damage
- Tap shank square engages with square drive socket
- 3 set screws secure tap in holder

Order Number	Morse Taper	Tap Size	Tap Shank Diameter	Tap Shank Square
70308	3	5/8"	.480	.366
70301	3	3/4"	.590	.442
70302	3	7/8"	.697	.523
70303	3	1"	.800	.600
70304	3	1-1/8"	.896	.672
70403	4	1"	.800	.600
70404	4	1-1/8"	.896	.672
70405	4	1-1/4"	1.021	.766
70406	4	1-3/8"	1.108	.831
70407	4	1-1/2"	1.233	.925
70408	4	1-5/8"	1.305	.979



Part No. **GSW-444** quick-change tapping chuck with MT4 connection (for MAB 1300). Collets not included. *GSW-444 and GSS-4xx collet set shown below.*

- GSS-420** collet for 20mm shanks
- GSS-422** collet for 22mm shanks
- GSS-427** collet for 27mm shanks
- GSS-433** collet for 33mm shanks
- GSS-442** collet for 42mm shanks



See page 43 for additional tapping options.

Tap Collets and Reducing Adapters



Tap Collets with 3/4" or 1-1/4" Weldon shank
all threads shown are ASA Standard (or DIN 376 for metric)

Thread	Order No.	Thread	Order No.
1/4	ZGA 1/4	9/16	ZGA 9/16
5/16	ZGA 5/16	5/8	ZGA 5/8
3/8	ZGA 3/8	11/16	ZGA 11/16
7/16	ZGA 7/16	3/4	ZGA 3/4
1/2	ZGA 1/2		

Bushing – Reduces 1-1/4" Weldon shank to 3/4" Weldon shank
Order No. **ZAP 200**



Reducing Sleeve
DIN 2185
Order No. **ZRH 430** for MT 4:3
(adapts MT4 to MT3)



► *Annular Cutters: pages 32-41* ► *Accessories: pages 42-50*

CSU 32RL

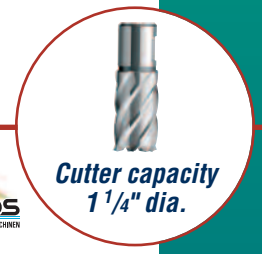
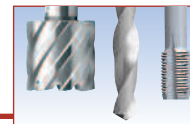

Best power-to-weight performance in the industry



Powerful • Reliable

- Strong 8.2 Amp motor
- Compact, lightweight and portable – 14-1/4" high, 24 lbs.
- Designed for continuous use
- Variable speed

Drill up to 1-1/4" dia.

- Uses annular cutters; 5-3/4" stroke
- Twist drilling up to 1/2" dia.; 6-1/2" stroke with chuck
- Tapping up to 3/4" dia.*
- Automatic lubrication system

REVERSIBLE

Model CSU 32RL has a variable-speed (100-450 RPM), reversible motor for tapping up to 3/4"



Integrated Safety

- SafeMag™ Green/Red LED magnetic force indicator for safe operation
- Equipped with CoolMag™ overheat protection
- Emergency-off function



With included 1/2" chuck (Part No. IBC 17), this model easily converts to standard drill presses with a 6 1/2" stroke for conventional twist drills.



Tap collet set included with Model CSU 32RL

Standard Equipment includes auto lubrication, auto chuck cutter holder, 1/2" geared chuck, safety chain, carabin hook, allen keys, pilot pins and carrying case.

CSU 32RL Specifications

Motor Power	8.2 Amp / 110 Volt
Weight	24 lbs.
Hole Capacity	1 1/4" dia.
Twist Drill Capacity	1/2" dia.
Tapping Capacity	3/4"
Speed	450 RPM
Magnet Base Size	6 5/16" W x 3 1/4" H
Dimensions	14 1/4" H x 9 1/2" L x 4 3/8" W
Magnetic Force (1" plate)	3080 lbs.
Arbor Bore	3/4" Weldon Shank
Spindle	1/2"-20 UNF Thread
Automatic Lubrication	Included
Power Assist	Order Accessory ZPA 401

➤ *Annular Cutters: pages 32-41* ➤ *Accessories: pages 42-50*



Cutter capacity
2" dia.

CSU 50AC & CSU 50RL

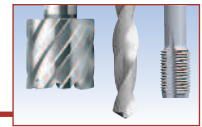

Lightweight, two-speed, high-performance drills



Powerful • Reliable

- Strong 10.5 Amp motor
- Compact, lightweight and portable – 16-1/2" high, 29 lbs.
- 2-gear variable speed gearbox
- Designed for continuous use

Drill up to 2" dia.

- Uses annular cutters; 5-1/4" stroke
- Twist drilling up to 7/8" dia.
- Tapping up to 15/16" dia.*
- Automatic lubrication system

Keyless Cutter Mount

- Easy "twist and lock" keyless arbor
- Also includes manual arbor for 3/4" Weldon shank (MT2) with set screws



Integrated Safety

- SafeMag™ Green/Red LED magnetic force indicator for safe operation
- Equipped with CoolMag™ overheat protection
- Emergency-off function



With included 3/4" chuck (Part No. IBC 22) or MT2, these models easily convert to standard drill presses with a 4 1/2" stroke for conventional twist drills.

REVERSIBLE

Model CSU 50RL has a variable-speed, reversible motor for tapping up to 15/16"

Optional quick-change tapping chuck with MT2 connection (Model GSW-222) has flexible collet to fit taps 5/16" to 5/8"



Tap collet set included with Model CSU 50RL

Standard Equipment includes auto lubrication, auto chuck cutter holder, manual chuck with set screws, 1/2" geared chuck, safety chain, carabin hook, allen keys, pilot pins and carrying case. (CSU 50RL shown)

CSU 50AC Specifications

Motor Power	10.5 Amp / 110 Volt
Weight	29 lbs.
Hole Capacity	2" dia.
Twist Drill Capacity	7/8" dia.
Tapping Capacity	15/16" (CSU 50RL only)
Speeds	1: 250 RPM, 2: 450 RPM
Magnet Base Size	6 1/2" W x 3 1/2" H
Dimensions	16 1/2" H x 9" L x 6 3/8" W
Magnetic Force (1" plate)	3750 lbs.
Arbor Bore	3/4" Weldon Shank
Spindle	MT2
Automatic Lubrication	Included
Reversible Motor	Order CSU 50RL
Power Assist	Order Accessory ZPA 401

* Model CSU 50RL for tapping up to 15/16" dia.

➤ **Annular Cutters:** pages 32-41 ➤ **Accessories:** pages 42-50

CSU 80AC & CSU 100/3RL



Cutter capacity
3³/₁₆" & 4" dia.

CSU 80AC

Powerful high-torque motor
with multiple speeds



With included 3/4" chuck (Part No. IBC 21) or MT3, this model easily converts to a standard drill press with a stroke of 6 1/2".



CSU 100/3RL

Powerful reversible motor for
drilling and tapping



REVERSIBLE

2 Gears with Variable Speed



Twist Drilling



Tapping



Reaming



Countersinking



Optional MT3 tapping chuck with two variable clamp collets (Model GSW-830C) fits taps 3/8" to 1-1/8"



CSU 80AC Specifications

Motor Power	15 Amp / 110 Volt*
Weight	57 lbs.
Hole Capacity	3 ³ / ₁₆ " dia.
Twist Drill Capacity	1 1/4" dia.
Speeds	1: 100 RPM, 2: 175 RPM 3: 245 RPM, 4: 385 RPM
Magnet Base Size	9" W x 4 ³ / ₈ " H
Dimensions	19 1/2" H x 13 ³ / ₈ " L x 7 1/2" W
Magnetic Force (1" plate)	7040 lbs.
Arbor Bore	3/4" (1 1/4" also available)
Spindle	MT3
Automatic Lubrication	Included
Power Assist	Order Accessory ZPA 402

* 220 Volt / 50 Hz also available

Standard Equipment includes auto lubrication, auto chuck cutter holder, manual chuck with set screws, safety chain, carabin hook, allen keys, pilot pins and carrying case[†].

[†] Steel case intended mainly for shipping purposes; damage may occur in transit.

CSU 100/3RL Specifications

Motor Power	16 Amp / 110 Volt*
Weight	57 lbs.
Hole Capacity	4" dia.
Twist Drill Capacity	1 1/4" dia.
Tapping Capacity	1 1/8" dia.
Speeds (variable)	40-140 RPM, 120-480 RPM
Magnet Base Size	9" W x 4" H
Dimensions	19 1/2" H x 13 ³ / ₈ " L x 7 1/2" W
Magnetic Force (1" plate)	6600 lbs.
Arbor Bore	3/4" (1 1/4" also available)
Spindle	MT3
Automatic Lubrication	Included
Power Assist	Order Accessory ZPA 402

* 220 Volt / 50 Hz also available

➤ **Annular Cutters:** pages 32-41 ➤ **Accessories:** pages 42-50



Cutter capacity
2 1/16" dia.

AIRBOR™ AB-4300

Motor and magnet
are powered completely
by compressed air

Pneumatic power for hazardous environments

ATEX Classified

Safe • Reliable

- Inherently safer than electromagnetic drills in hazardous atmospheres and wet environments where electricity requires "hot work permits"
- ATEX classified
- Industry's first completely air-operated magnetic drill – NO ELECTRICITY!
- Fail-safe permanent magnet is activated "on" and "off" by air pressure; in the event of a loss of air flow, the magnet *will not* disengage
- 1600 lbs. magnet holding strength

Drill up to 2-1/16" dia.

- Uses annular cutters
- Twist drilling up to 5/8"
- Powerful 1.6 HP drill motor
- Long drill stroke – up to 10 1/4"
- Pressurized coolant system lubricates cutter and reduces risk of sparking



Model AB-4300-2



With a geared chuck adapter (Part No. IBC 18) and extra rack (Model No. AB-4300-2R), AIRBOR™ easily converts to a standard drill press with a 7 1/2" stroke.



Pressurized lubrication system (Part No. 9 4002 0020)



AB-4300-2R shown with extra rack up (left) and extra rack down (right).

Model Comparison

AB-4300-2R		AB-4300-2	
<i>Drill Stroke</i>			
w/cutters	w/chuck	w/cutters	w/chuck
10 1/4"	7 1/2"	4 7/8"	1 3/4"
<i>Height</i>			
closed	open	closed	open
13 1/2"	22"	13 1/2"	17 1/2"
<i>Weight</i>			
lbs.	kg	lbs.	kg
43	20	38	18

Cutter Capacity



ø 2 1/16"

Twist Drill / Countersink



1/2"

Stroke (length)

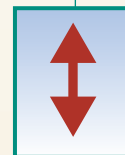

Up to 10 1/4"

Speed Range (RPM)



400

Model AB-4300-2 / AB-4300-2R Specifications

Motor Power (Pneumatic)	1.6 HP
Air Consumption @ 90 PSI	64 CFM (1/2" NPT Air Connection)
Hole Capacity	2 1/16" dia.
No Load Speed	400 RPM
Magnet Base Size	8 3/4" W x 3 1/2" L
Dimensions	13 1/2" H x 12 1/2" L x 4 3/4" W
Magnetic Force (1" plate)	1600 lbs.
Arbor Bore	3/4" Weldon Shank
Automatic Lubrication	Included
Stroke Length 4 7/8"	Order Model AB-4300-2
Stroke Length 10 1/4"	Order Model AB-4300-2R

► Annular Cutters: pages 32-41 ► Accessories: pages 42-50

HB 4400 for Subsea Drilling



Hydraulic for marine and construction – works underwater

Safe • Reliable





- Ideal for industrial, construction, marine and mining applications
- Drill structural steel and other metals
- Hydraulic motor safe for underwater use
- Manually operated permanent magnet with ratchet control has holding strength of 1300 lbs.

Drill up to 2-1/16" dia.

- Uses annular cutters
- Twist drilling up to 1/2" dia.
- Automatic lubrication

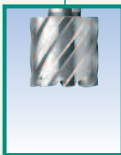

With a 3/4" chuck (Part No. 602045A), this model easily converts to a standard drill press with a 3" stroke.

Cutter Capacity	Twist Drill / Countersink	Stroke (length)	Speed Range (RPM)
			
Ø 2 1/16"	1/2"	Up to 3 3/4"	0-630

Model HB 4400
Hoses not included



Model HB 4400 Specifications

Motor Power (Hydraulic)	1.5 HP
Weight	48 1/2 lbs.
Hole Capacity	2 1/16" dia.
Twist Drill Capacity	1/2" dia.
No Load Speed, Variable	0-630 RPM
Hydraulic Supply	Flow 6.5 GPM @ 2000 PSI
Magnet Base Size	7 1/4" W x 3" L
Dimensions	18 1/2" H x 12 1/2" L x 7" W
Magnetic Force (1" plate)	1300 lbs.
Automatic Lubrication	Included

➤ *Annular Cutters: pages 32-41* ➤ *Accessories: pages 42-50*

Annular Cutters

Achieve burr-free finished holes, without predrilling or stepdrilling

Precision-ground flutes provide efficient chip clearance, increasing drilling productivity and decreasing cutter breakage

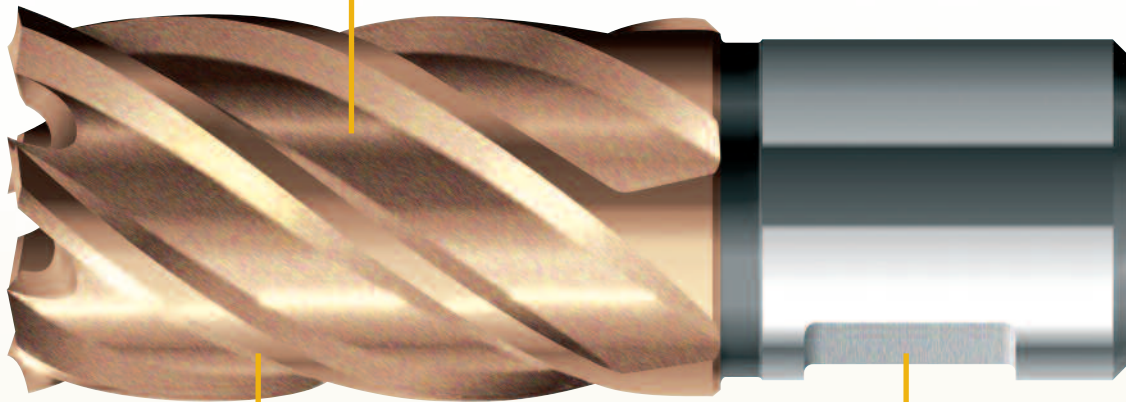

Hardened, high-speed tool steel

Weldon Shank

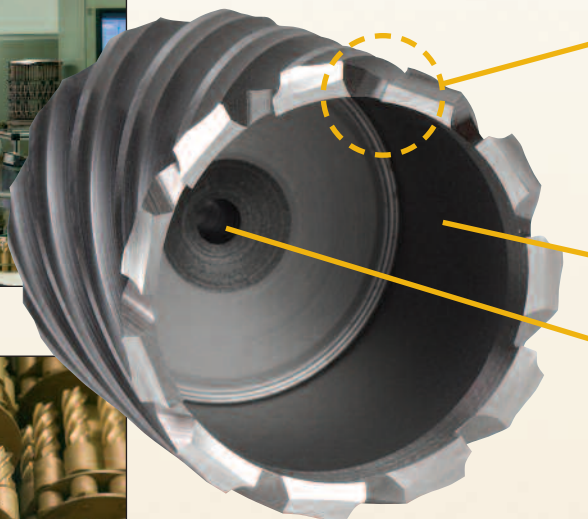

Benefits of CS Unitec's Cutter Design:

Double-action tooth geometry cuts, splits and ejects chips more efficiently,

- increasing cutting speed
- reducing tooth load
- minimizing tool wear
- lengthening cutter life

Engineered with a tapered inner wall for smooth, easy slug ejection.

Center hole for pilot pin accurately aligns the cutter, allows for internal lubrication and removes the slug.

Perfect drilling to close tolerances without runout.
The result: a burr-free finished hole.



Pilot Pins: How they work...

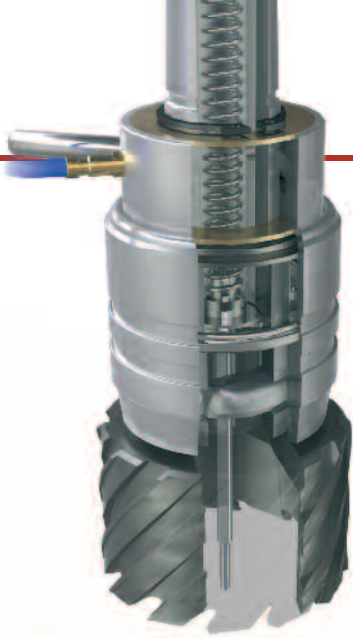

1: Centering

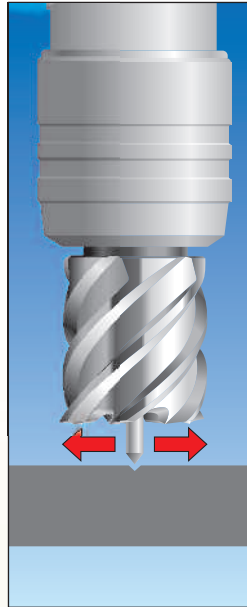

The pilot pin accurately centers cutter over area to be drilled.

2: Oiling

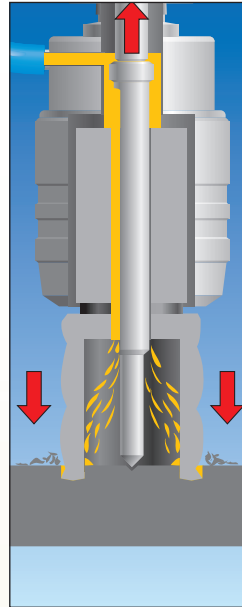

During drilling, the pilot pin retracts and allows internal coolant to reach the cutting teeth.

3: Ejecting

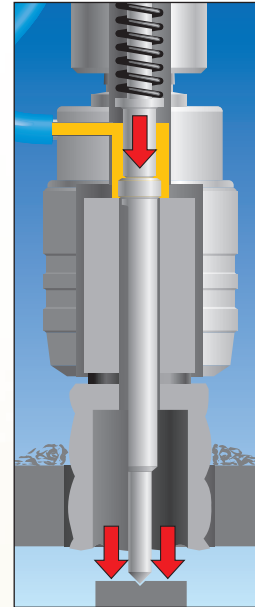

When hole is complete, the slug is automatically ejected from the cutter.

6-Series HSS Unibroach™ Annular Cutters – Pages 34-35

Fully ground HSS annular cutters

Cutting depth:	1"	2"	3"	4"
Drilling ø:	7/16" - 5-1/8"	7/16" - 5-1/8"	3/4" - 5-1/8"	3/4" - 5-1/8"

8-Series ARMOR-PLATED Unibroach™ Annular Cutters – Pages 36-37

Fully ground HSS annular cutters with TiAlN hard coating

Cutting depth:	1"	2"	3"
Drilling ø:	7/16" - 5-1/8"	7/16" - 5-1/8"	3/4" - 5-1/8"

9-Series Unibroach™ TCT Hornet Annular Cutters – Pages 38-39

Sintered carbide annular cutters with Tungsten Carbide tips

Cutting depth:	1"*	2-3/8"	3-3/8"	4"	6"	8"
Drilling ø:	1/2" - 2"	1/2" - 5-1/8"	3/4" - 5-1/8"	3/4" - 5-1/8"	3/4" - 5-1/8"	3/4" - 5-1/8"

* 1-3/8" depth for diameters larger than 1-1/2"

For Cobalt Cutters, Rail Cutters and special sizes, see page 40. For One-Touch TCT Cutters, see page 41.



➤ See pages 42-50 for Drill Accessories.

Unibroach® Annular Cutters

High-speed steel for drilling 3x faster than twist drills

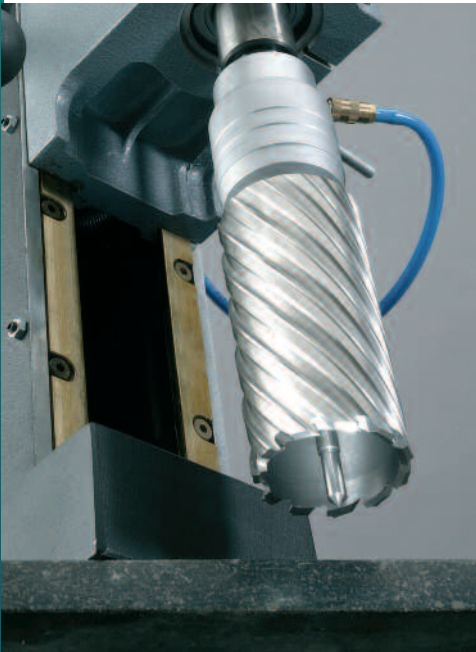

Annular Cutters are the standard hole-making drills in the industry. Ideal for heavy-duty use on-site or in the shop, our HSS Unibroach™ cutters are available in the following sizes:

Drill Depth	1"	2"	3"	4"	6"	8"
Diameter	∅ 7/16" to ∅ 5 1/8"	∅ 7/16" to ∅ 5 1/8"	∅ 3/4" to ∅ 5 1/8"	∅ 3/4" to ∅ 5 1/8"	∅ 3/4" to ∅ 5 1/8"	∅ 3/4" to ∅ 5 1/8"

*Special sizes available; metric cutters available on request.
Every annular cutter includes a corresponding pilot pin.*

- CNC precision ground for fast penetration, accuracy and long life
- Flutes run the length of the cutter for efficient chip clearance, increased drilling productivity and decreased cutter breakage
- Drill holes 3 times faster than twist drills
- Produce reamed-quality, burr-free holes and solid slugs
- Reduce machine size and weight
- Cutting edges are resharpenable
- Eliminate time-consuming, costly pilot holes and step drilling

**Annular Cutter
Recommended
Revolutions Per Minute**

Recommended Feed Rate:
.002 - .004 inches per revolution

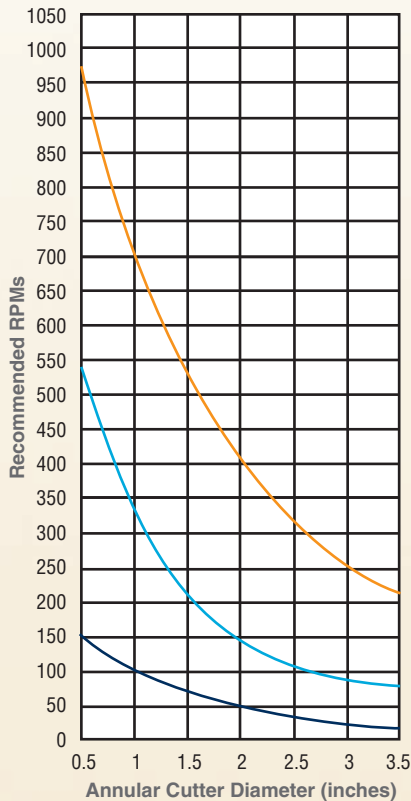

Aluminum
200 ft./min.

Mild Steel
(Carbon)
80 ft./min.

High Tensile
Steel
(Stainless)
30 ft./min.



See page 46 for HSS
Annular Cutter Starter Kit.



* HSS Cutters must be used with lubricant.
See page 42 for CS Unitec lubricants and cutting oil.

Unibroach® Stack Cutters are available in diameters from 9/16" to 1 1/8" in 1", 2" and 3" depths. Drill multiple layers of steel without stopping to remove the center slug. Please contact us or consult our price list for more information.

6-Series HSS

1" Depth

Order No.	Diameter
6-1-114	7/16"
6-1-116	1/2"
6-1-118	9/16"
6-1-120	5/8"
6-1-122	11/16"
6-1-124	3/4"
6-1-126	13/16"
6-1-128	7/8"
6-1-130	15/16"
6-1-132	1"
6-1-134	1-1/16"
6-1-136	1-1/8"
6-1-138	1-3/16"
6-1-140	1-1/4"
6-1-142	1-5/16"
6-1-144	1-3/8"
6-1-146	1-7/16"
6-1-148	1-1/2"
6-1-150	1-9/16"
6-1-152	1-5/8"
6-1-154	1-11/16"
6-1-156	1-3/4"
6-1-158	1-13/16"
6-1-160	1-7/8"
6-1-162	1-15/16"
6-1-164	2"
6-1-166	2-1/16"
6-1-168	2-1/8"
6-1-170	2-3/16"
6-1-172	2-1/4"
6-1-174	2-5/16"
6-1-176	2-3/8"
6-1-178	2-7/16"
6-1-180	2-1/2"
6-1-182	2-9/16"
6-1-184	2-5/8"
6-1-186	2-11/16"
6-1-188	2-3/4"
6-1-190	2-13/16"
6-1-192	2-7/8"
6-1-194	2-15/16"
6-1-196	3"
6-1-198	3-1/16"
6-1-1100	3-1/8"
6-1-1102	3-3/16"
6-1-1104	3-1/4"
6-1-1106	3-5/16"
6-1-1108	3-3/8"
6-1-1110	3-7/16"
6-1-1112	3-1/2"
6-1-1114	3-9/16"
6-1-1116	3-5/8"
6-1-1118	3-11/16"
6-1-1120	3-3/4"
6-1-1122	3-13/16"
6-1-1124	3-7/8"
6-1-1126	3-15/16"
6-1-1128	4"

2" Depth

Order No.	Diameter
6-1-214	7/16"
6-1-216	1/2"
6-1-218	9/16"
6-1-220	5/8"
6-1-222	11/16"
6-1-224	3/4"
6-1-226	13/16"
6-1-228	7/8"
6-1-230	15/16"
6-1-232	1"
6-1-234	1-1/16"
6-1-236	1-1/8"
6-1-238	1-3/16"
6-1-240	1-1/4"
6-1-242	1-5/16"
6-1-244	1-3/8"
6-1-246	1-7/16"
6-1-248	1-1/2"
6-1-250	1-9/16"
6-1-252	1-5/8"
6-1-254	1-11/16"
6-1-256	1-3/4"
6-1-258	1-13/16"
6-1-260	1-7/8"
6-1-262	1-15/16"
6-1-264	2"
6-1-266	2-1/16"
6-1-268	2-1/8"
6-1-270	2-3/16"
6-1-272	2-1/4"
6-1-274	2-5/16"
6-1-276	2-3/8"
6-1-278	2-7/16"
6-1-280	2-1/2"
6-1-282	2-9/16"
6-1-284	2-5/8"
6-1-286	2-11/16"
6-1-288	2-3/4"
6-1-290	2-13/16"
6-1-292	2-7/8"
6-1-294	2-15/16"
6-1-296	3"
6-1-298	3-1/16"
6-1-2100	3-1/8"
6-1-2102	3-3/16"
6-1-2104	3-1/4"
6-1-2106	3-5/16"
6-1-2108	3-3/8"
6-1-2110	3-7/16"
6-1-2112	3-1/2"
6-1-2114	3-9/16"
6-1-2116	3-5/8"
6-1-2118	3-11/16"
6-1-2120	3-3/4"
6-1-2122	3-13/16"
6-1-2124	3-7/8"
6-1-2126	3-15/16"
6-1-2128	4"

3" Depth*

Order No.	Diameter
N/A	
N/A	
N/A	
N/A	
N/A	
6-1-324	3/4"
6-1-326	13/16"
6-1-328	7/8"
6-1-330	15/16"
6-1-332	1"
6-1-334	1-1/16"
6-1-336	1-1/8"
6-1-338	1-3/16"
6-1-340	1-1/4"
6-1-342	1-5/16"
6-1-344	1-3/8"
6-1-346	1-7/16"
6-1-348	1-1/2"
6-1-350	1-9/16"
6-1-352	1-5/8"
6-1-354	1-11/16"
6-1-356	1-3/4"
6-1-358	1-13/16"
6-1-360	1-7/8"
6-1-362	1-15/16"
6-1-364	2"
6-1-366	2-1/16"
6-1-368	2-1/8"
6-1-370	2-3/16"
6-1-372	2-1/4"
6-1-374	2-5/16"
6-1-376	2-3/8"
6-1-378	2-7/16"
6-1-380	2-1/2"
6-1-382	2-9/16"
6-1-384	2-5/8"
6-1-386	2-11/16"
6-1-388	2-3/4"
6-1-390	2-13/16"
6-1-392	2-7/8"
6-1-394	2-15/16"
6-1-396	3"
6-1-398	3-1/16"
6-1-3100	3-1/8"
6-1-3102	3-3/16"
6-1-3104	3-1/4"
6-1-3106	3-5/16"
6-1-3108	3-3/8"
6-1-3110	3-7/16"
6-1-3112	3-1/2"
6-1-3114	3-9/16"
6-1-3116	3-5/8"
6-1-3118	3-11/16"
6-1-3120	3-3/4"
6-1-3122	3-13/16"
6-1-3124	3-7/8"
6-1-3126	3-15/16"
6-1-3128	4"

* Cutters with 3" depth have an 8mm dia. pilot hole.

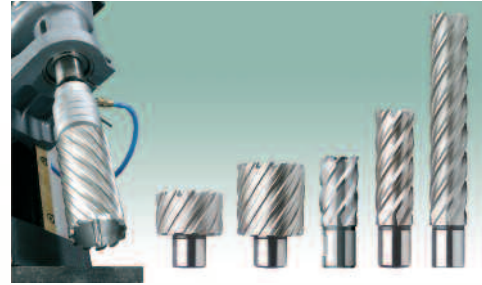

Shank size:

**3/4" for cutters up to 3" dia.
1-1/4" for cutters 3-1/16 to 5-1/8" dia.**

Pilot pin included with every annular cutter

Cutter Kits

Each HSS steel cutter kit comes with the following: 9/16", 11/16", 13/16", 15/16", 1-1/16", pilot pins & carrying case.

Order No.	Description
6-1-001	1" depth Cutter Kit
6-1-002	2" depth Cutter Kit

Pilot Pins for 6-Series

Order No.	Description
For 3/4" Shanks	
7-3-102	1/2" - 3" dia., 1" depth
7-3-202	1/2" - 3" dia., 2" depth
7-3-302	3/4" - 3" dia., 3" depth
For 1-1/4" Shanks	
7-3-1002	3-1/16" - 5" dia., 1" depth
7-3-2002	3-1/16" - 5" dia., 2" depth
7-3-3002	3-1/16" - 5" dia., 3" depth

Option for Cutters 3" and 4" Depth

7-3-402	2-piece pin for 3" and 4" depth cutters with 8mm pilot hole.
---------	--

† We also stock 4" depth HSS cutters and Metric HSS cutters. Larger diameters and special sizes available upon request. Please call us for pricing and delivery.



➤ See pages 42-50 for Drill Accessories.

Unibroach® Annular Cutters

TiAlN coating for up to 4x tool life, less friction and more power
Less Friction = Less Heat = More Holes!

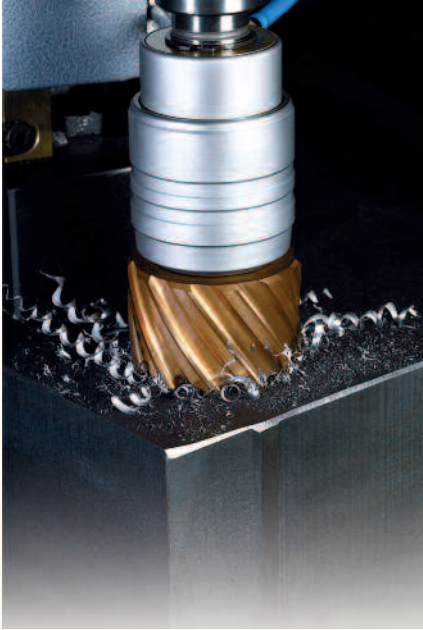

ARMOR-PLATED Unibroach™ Cutters, at 90Rc hardness, are the state-of-the-art in hole cutting technology. They multiply service life, reduce cost and increase productivity.

ARMOR-PLATED Unibroach™ cutters are available in the following sizes:

Drill Depth	1"	2"	3"
Diameter	∅ 7/16" to ∅ 5 1/8"	∅ 7/16" to ∅ 5 1/8"	∅ 3/4" to ∅ 5 1/8"



Special sizes available; metric cutters available on request.
Every annular cutter includes a corresponding pilot pin.

- 3 to 4 times longer tool life with TiAlN coating
- Drill with less friction and more power
- Withstands higher working temperatures – up to 1480°F (800°C)
- Dry drilling or lubricating with water simplifies working conditions and cleanup*
- Prevents cold weld – metal chips do not adhere to the cutter
- Ideal for structural steel and hard metal
- 3/4" dia. shank (1 1/4" dia. shank available)

* After the TiAlN coating is worn, lubricate with cutting oil

Annular Cutter Recommended Revolutions Per Minute
 Recommended Feed Rate:
 .002 - .004 inches per revolution

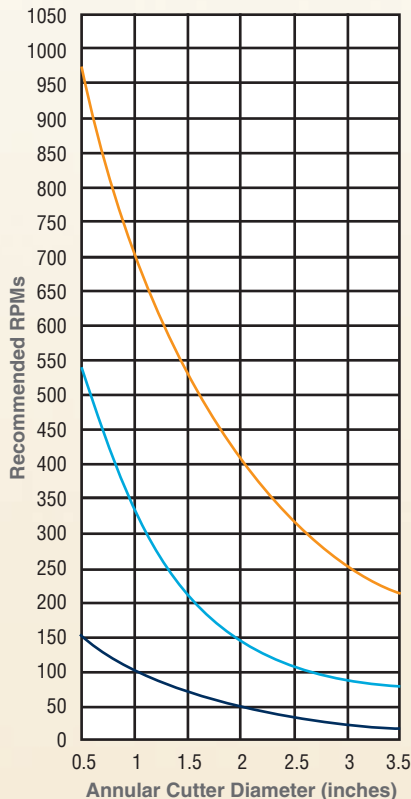

Aluminum
200 ft./min.

Mild Steel (Carbon)
80 ft./min.

High Tensile Steel (Stainless)
30 ft./min.

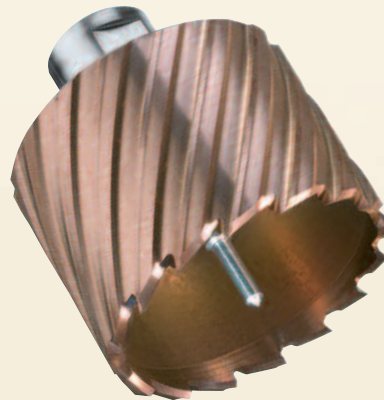

See page 46 for ARMOR-PLATED Unibroach™ TiAlN Annular Cutter Starter Kit.

8-Series ARMOR-PLATED TiAIN

ARMOR-PLATED = Less Friction = Less Heat = More Holes!
Increase tool life and achieve faster feed rates



Shank size: 3/4" up to 3" dia.

ARMOR-PLATED Unibroach™ Cutters, at 90Rc hardness, are the state-of-the-art in hole cutting technology. They multiply service life, reduce cost and increase productivity.



Pilot pin included with every annular cutter

1" Depth	
Order No.	Diameter
8-1-114 T	7/16"
8-1-116 T	1/2"
8-1-118 T	9/16"
8-1-120 T	5/8"
8-1-122 T	11/16"
8-1-124 T	3/4"
8-1-126 T	13/16"
8-1-128 T	7/8"
8-1-130 T	15/16"
8-1-132 T	1"
8-1-134 T	1-1/16"
8-1-136 T	1-1/8"
8-1-138 T	1-3/16"
8-1-140 T	1-1/4"
8-1-142 T	1-5/16"
8-1-144 T	1-3/8"
8-1-146 T	1-7/16"
8-1-148 T	1-1/2"
8-1-150 T	1-9/16"
8-1-152 T	1-5/8"
8-1-154 T	1-11/16"
8-1-156 T	1-3/4"
8-1-158 T	1-13/16"
8-1-160 T	1-7/8"
8-1-162 T	1-15/16"
8-1-164 T	2"
8-1-166 T	2-1/16"

2" Depth	
Order No.	Diameter
8-1-214 T	7/16"
8-1-216 T	1/2"
8-1-218 T	9/16"
8-1-220 T	5/8"
8-1-222 T	11/16"
8-1-224 T	3/4"
8-1-226 T	13/16"
8-1-228 T	7/8"
8-1-230 T	15/16"
8-1-232 T	1"
8-1-234 T	1-1/16"
8-1-236 T	1-1/8"
8-1-238 T	1-3/16"
8-1-240 T	1-1/4"
8-1-242 T	1-5/16"
8-1-244 T	1-3/8"
8-1-246 T	1-7/16"
8-1-248 T	1-1/2"
8-1-250 T	1-9/16"
8-1-252 T	1-5/8"
8-1-254 T	1-11/16"
8-1-256 T	1-3/4"
8-1-258 T	1-13/16"
8-1-260 T	1-7/8"
8-1-262 T	1-15/16"
8-1-264 T	2"
8-1-266 T	2-1/16"

3" Depth*	
Order No.	Diameter
N/A	
N/A	
N/A	
N/A	
N/A	
8-1-324 T	3/4"
8-1-326 T	13/16"
8-1-328 T	7/8"
8-1-330 T	15/16"
8-1-332 T	1"
8-1-334 T	1-1/16"
8-1-336 T	1-1/8"
8-1-338 T	1-3/16"
8-1-340 T	1-1/4"
8-1-342 T	1-5/16"
8-1-344 T	1-3/8"
8-1-346 T	1-7/16"
8-1-348 T	1-1/2"
8-1-350 T	1-9/16"
8-1-352 T	1-5/8"
8-1-354 T	1-11/16"
8-1-356 T	1-3/4"
8-1-358 T	1-13/16"
8-1-360 T	1-7/8"
8-1-362 T	1-15/16"
8-1-364 T	2"
8-1-366 T	2-1/16"

* Cutters with 3" depth have an 8mm dia. pilot hole.

ARMOR-PLATED Cutter Kits

Each armor-plated cutter kit comes with the following: 9/16", 11/16", 13/16", 15/16", 1-1/16", pilot pins & carrying case.

Order No.	Description
8-1-001 T	1" depth Cutter Kit
8-1-002 T	2" depth Cutter Kit

Pilot Pins for 8-Series

Order No.	Description
For 3/4" Shanks	
7-3-102	1/2" - 3" dia., 1" depth
7-3-202	1/2" - 3" dia., 2" depth
7-3-302	3/4" - 3" dia., 3" depth

Option for Cutters 3" and 4" Depth

	
7-3-402	2-piece pin for 3" and 4" depth cutters with 8mm pilot hole.

3"+ Diameter Cutters

Metric and larger diameter cutters available on request.

ARMOR-PLATED Unibroach™ TiAIN Cutters:

- Drill with less friction and more power
- Withstand higher working temperatures – up to 1480°F (800°C)
- Dry drill or lubricate with water to simplify working conditions and cleanup**
- Prevent cold weld – metal chips do not adhere to the cutter
- Are ideal for structural steel and hard metal

** After the TiAIN coating is worn, lubricate with cutting oil

➤ See pages 42-50 for Drill Accessories.

Unibroach® Annular Cutters

ANNULAR CUTTERS

TCT Carbide Hornet – tungsten carbide-tipped for high-speed cutting



- Use high-speed RPM for best results and faster holmaking
- Ideal for drilling steel with rust or paint and bolting applications
- Will outlast High-speed Steel cutters
- Leaves a burr-free finished hole
- Available in all sizes (fractional and metric)
- 2 flats
- 3/4" or 1 1/4" shank

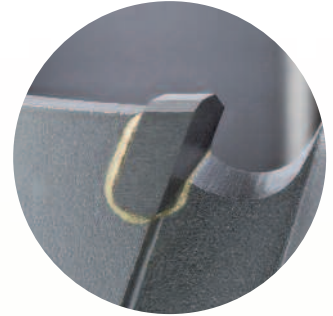

Closeup of tungsten-carbide teeth.

TCT Hornet cutters are available in the following sizes:

Drill Depth	1"	1-3/8"	2-3/8"	3-3/8"	4"	6"	8"
Diameter	Ø 1/2" to Ø 1 1/2"	Ø 1 9/16" to Ø 2"	Ø 1 1/2" to Ø 5 1/8"	Ø 3/4" to Ø 5 1/8"	Ø 3/4" to Ø 5 1/8"	Ø 1 3/16" to Ø 5 1/8"	Ø 1 3/16" to Ø 5 1/8"

*Special sizes available; metric cutters available on request.
Every annular cutter includes a corresponding pilot pin.*



Armor plating available upon request.

9-Series Annular Cutter Recommended RPM Rates

Cutter Size	Stainless & Alloy Steel	Mild Steel	Iron Plate
	RPM	RPM	RPM
1/2" - 5/8"	500 - 800	600 - 1000	800 - 1200
1 1/16" - 1 3/16"	400 - 640	480 - 800	640 - 960
7/8" - 1 5/16"	330 - 530	400 - 660	530 - 800
1" - 1 3/16"	270 - 420	320 - 530	420 - 640
1 1/4" - 1 3/8"	230 - 370	270 - 460	360 - 550
1 7/16" - 1 9/16"	200 - 320	240 - 400	320 - 480
1 5/8" - 1 3/4"	180 - 280	210 - 350	280 - 420
1 13/16" - 2"	160 - 260	190 - 320	260 - 380
2 1/16" - 2 3/16"	145 - 230	170 - 290	230 - 350
2 1/4" - 2 3/8"	135 - 210	160 - 270	210 - 320
2 7/16" - 2 9/16"	120 - 200	150 - 250	200 - 300
2 5/8" - 2 3/4"	115 - 180	140 - 230	180 - 270
2 13/16" - 2 15/16"	110 - 170	130 - 210	170 - 260
3" - 3 1/8"	100 - 160	120 - 200	160 - 240
3 3/16" - 3 3/8"	95 - 150	115 - 190	150 - 230
3 7/16" - 3 9/16"	90 - 140	110 - 180	140 - 210
3 5/8" - 3 3/4"	85 - 135	105 - 170	135 - 200
3 13/16" - 3 15/16"	80 - 130	95 - 160	130 - 195
4" - 4 5/16"	70 - 120	90 - 145	120 - 170
4 3/8" - 4 3/4"	70 - 110	80 - 135	110 - 160
4 13/16" - 5 1/8"	65 - 100	75 - 125	100 - 150

9-Series - TCT Carbide Hornet

1" Depth

Order No.	Diameter
9-1-116 C	1/2"
9-1-118 C	9/16"
9-1-120 C	5/8"
9-1-122 C	11/16"
9-1-124 C	3/4"
9-1-126 C	13/16"
9-1-128 C	7/8"
9-1-130 C	15/16"
9-1-132 C	1"

Order No.	Diameter
9-1-134 C	1-1/16"
9-1-136 C	1-1/8"
9-1-138 C	1-3/16"
9-1-140 C	1-1/4"
9-1-142 C	1-5/16"
9-1-144 C	1-3/8"
9-1-146 C	1-7/16"
9-1-148 C	1-1/2"

2-3/8" Depth

Order No.	Diameter
9-1-216 C	1/2"
9-1-218 C	9/16"
9-1-220 C	5/8"
9-1-222 C	11/16"
9-1-224 C	3/4"
9-1-226 C	13/16"
9-1-228 C	7/8"
9-1-230 C	15/16"
9-1-232 C	1"
9-1-234 C	1-1/16"
9-1-236 C	1-1/8"
9-1-238 C	1-3/16"
9-1-240 C	1-1/4"
9-1-242 C	1-5/16"
9-1-244 C	1-3/8"
9-1-246 C	1-7/16"
9-1-248 C	1-1/2"
9-1-250 C	1-9/16"
9-1-252 C	1-5/8"
9-1-254 C	1-11/16"
9-1-256 C	1-3/4"
9-1-258 C	1-13/16"
9-1-260 C	1-7/8"
9-1-262 C	1-15/16"
9-1-264 C	2"

Order No.	Diameter
9-1-266 C	2-1/16"
9-1-268 C	2-1/8"
9-1-270 C	2-3/16"
9-1-272 C	2-1/4"
9-1-274 C	2-5/16"
9-1-276 C	2-3/8"
9-1-278 C	2-7/16"
9-1-280 C	2-1/2"
9-1-282 C	2-9/16"
9-1-284 C	2-5/8"
9-1-286 C	2-11/16"
9-1-288 C	2-3/4"
9-1-290 C	2-13/16"
9-1-292 C	2-7/8"
9-1-294 C	2-15/16"
9-1-296 C	3"
9-1-298 C	3-1/16"
9-1-2100 C	3-1/8"
9-1-2102 C	3-3/16"
9-1-2104 C	3-1/4"
9-1-2106 C	3-5/16"
9-1-2108 C	3-3/8"
9-1-2110 C	3-7/16"
9-1-2112 C	3-1/2"

3-3/8" Depth

Order No.	Diameter
9-1-324 C	3/4"
9-1-326 C	13/16"
9-1-328 C	7/8"
9-1-330 C	15/16"
9-1-332 C	1"
9-1-334 C	1-1/16"
9-1-336 C	1-1/8"
9-1-338 C	1-3/16"
9-1-340 C	1-1/4"
9-1-342 C	1-5/16"
9-1-344 C	1-3/8"
9-1-346 C	1-7/16"
9-1-348 C	1-1/2"
9-1-350 C	1-9/16"
9-1-352 C	1-5/8"
9-1-354 C	1-11/16"
9-1-356 C	1-3/4"
9-1-358 C	1-13/16"
9-1-360 C	1-7/8"
9-1-362 C	1-15/16"
9-1-364 C	2"
9-1-366 C	2-1/16"
9-1-368 C	2-1/8"

Order No.	Diameter
9-1-370 C	2-3/16"
9-1-372 C	2-1/4"
9-1-374 C	2-5/16"
9-1-376 C	2-3/8"
9-1-378 C	2-7/16"
9-1-380 C	2-1/2"
9-1-382 C	2-9/16"
9-1-384 C	2-5/8"
9-1-386 C	2-11/16"
9-1-388 C	2-3/4"
9-1-390 C	2-13/16"
9-1-392 C	2-7/8"
9-1-394 C	2-15/16"
9-1-396 C	3"
9-1-398 C	3-1/16"
9-1-3100 C	3-1/8"
9-1-3102 C	3-3/16"
9-1-3104 C	3-1/4"
9-1-3106 C	3-5/16"
9-1-3108 C	3-3/8"
9-1-3010 C	3-7/16"
9-1-3112 C	3-1/2"
9-1-3114 C	3-9/16"
9-1-3116 C	3-5/8"

1-3/8" Depth

Order No.	Diameter
9-1-150 C	1-9/16"
9-1-152 C	1-5/8"
9-1-154 C	1-11/16"
9-1-156 C	1-3/4"
9-1-158 C	1-13/16"
9-1-160 C	1-7/8"
9-1-162 C	1-15/16"
9-1-164 C	2"

Order No.	Diameter
9-1-2114 C	3-9/16"
9-1-2116 C	3-5/8"
9-1-2118 C	3-11/16"
9-1-2120 C	3-3/4"
9-1-2122 C	3-13/16"
9-1-2124 C	3-7/8"
9-1-2126 C	3-15/16"
9-1-2128 C	4"
9-1-2130 C	4-1/16"
9-1-2132 C	4-1/8"
9-1-2134 C	4-3/16"
9-1-2136 C	4-1/4"
9-1-2138 C	4-5/16"
9-1-2140 C	4-3/8"
9-1-2142 C	4-7/16"
9-1-2144 C	4-1/2"
9-1-2146 C	4-9/16"
9-1-2148 C	4-5/8"
9-1-2150 C	4-11/16"
9-1-2152 C	4-3/4"
9-1-2154 C	4-13/16"
9-1-2156 C	4-7/8"
9-1-2158 C	4-15/16"
9-1-2160 C	5"
9-1-2162 C	5-1/8"

Order No.	Diameter
9-1-3118 C	3-11/16"
9-1-3120 C	3-3/4"
9-1-3122 C	3-13/16"
9-1-3124 C	3-7/8"
9-1-3126 C	3-15/16"
9-1-3128 C	4"
9-1-3130 C	4-1/16"
9-1-3132 C	4-1/8"
9-1-3134 C	4-3/16"
9-1-3136 C	4-1/4"
9-1-3138 C	4-5/16"
9-1-3140 C	4-3/8"
9-1-3142 C	4-7/16"
9-1-3144 C	4-1/2"
9-1-3146 C	4-9/16"
9-1-3148 C	4-5/8"
9-1-3150 C	4-11/16"
9-1-3152 C	4-3/4"
9-1-3154 C	4-13/16"
9-1-3156 C	4-7/8"
9-1-3158 C	4-15/16"
9-1-3160 C	5"
9-1-3162 C	5-1/8"



Shank size:

3/4" for cutters up to 3" dia.
1-1/4" for cutters 3-1/16 to 5-1/8" dia.

Pilot pin included with every annular cutter

Cutter Kits

Each hornet carbide cutter kit comes with the following: 9/16", 11/16", 13/16", 15/16", 1-1/16", pilot pins & carrying case.

Order No.	Description
9-1-001 C	1" depth Cutter Kit
9-1-002 C	2-3/8" depth Cutter Kit

****We also stock Metric Carbide cutters. Please call us for pricing and delivery. Larger diameters and special sizes are available upon request.**

Pilot Pins for 9-Series

Order No.	Description
For 3/4" Shanks	
9-3-102 C	5/8" - 2" dia., 1-3/8" depth
9-3-202 C	11/16" - 2-5/16" dia., 2" depth
9-3-302 C	13/16" - 2" dia., 3" depth

Order No.	Description
For 1-1/4" Shanks	
9-3-202A C	2-3/8" - 5-1/8" dia., 2" depth
9-3-302A C	2-3/8" - 5-1/8" dia., 3" depth

Option for Cutters 3" and 4" Depth

Order No.	Description
7-3-402	2-piece pin for 3" and 4" depth cutters with 8mm pilot hole.



➤ See pages 42-50 for Drill Accessories.

Unibroach® Annular Cutters

Unibroach® Large-Hole Cutting Cut holes up to 5-1/8" dia., 12" deep!



Large HSS,
TCT or M42
Cutters

Drill perfect holes up to 5 1/8" diameter without runoff

- Standard with 3/4" or 1 1/4" shank diameters
- More cutting teeth to distribute the load evenly – increase tool life and achieve faster feed rates
- Use on milling machines, drill presses, CNC and other equipment
- A solid slug has a higher value for scrap metal

Cut holes up to 5-1/8" dia. and 12" deep!
Available in TCT Carbide, HSS, Cobalt
and ARMOR-PLATED Unibroach™



4-Series Carbide-Tipped Rail Cutters Cut holes up to 1-11/16" dia. in track rail

- Carbide-tipped rail bits for long life and quick, efficient cutting through rust and corrosion
- Round, clean, burr-free hole – better than spade drills
- 3/4" shank
- More cutting teeth to distribute the load evenly – increase tool life and achieve faster feed rates
- Pilot pin included with each cutter
- Armor plating available upon request



1-3/8" Depth

Order No.	Diameter	Order No.	Diameter
4-1-124 C	3/4"	4-1-140 C	1-1/4"
4-1-128 C	7/8"	4-1-142 C	1-5/16"
4-1-130 C	15/16"	4-1-144 C	1-3/8"
4-1-132 C	1"	4-1-146 C	1-7/16"
4-1-134 C	1-1/16"	4-1-148 C	1-1/2"
4-1-136 C	1-1/8"	4-1-152 C	1-5/8"
4-1-138 C	1-3/16"	4-1-154 C	1-11/16"

Pilot Pin for 4-Series

Order No.	Description
For 3/4" Shanks	
4-3-102	5/8" - 2" dia., 1-3/8" depth

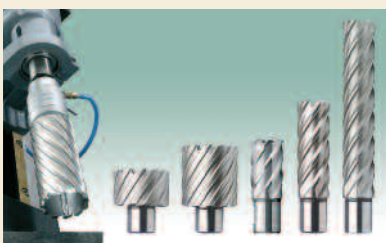

Unibroach® Cobalt Cutters

- 5% cobalt for increased wear resistance
- Excellent results when drilling high-tensile steel and difficult-to-machine materials
- Available with TiAlN coating upon request
- Available for hole sizes up to 5" dia.
- 3/4" shank is standard for cutters up to 3" dia.
- Metric cutters available on request
- See our price list for part numbers

10-Series One-Touch TCT

Tungsten carbide-tipped with one-touch shank

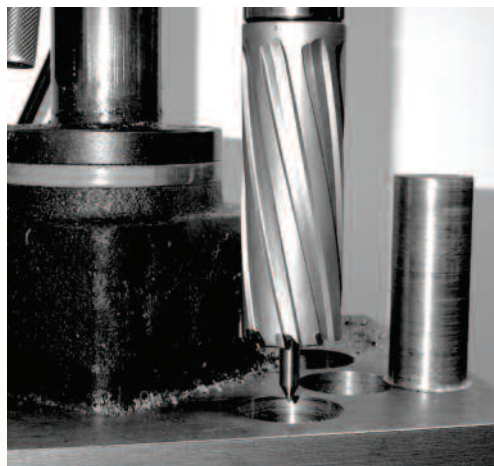

- No-tool cutter replacement
- When holding with a set screw, tighten to weld on flat rather than dimple area
- Leaves a burr-free finished hole
- 3/4" shank
- Compatible with Nitto Kohki and other auto-feed machines
- Armor plating also available upon request

Pilot pin included with every annular cutter



Shank size: 3/4"

Pilot Pins for 10-Series

Order No.	Description
For 3/4" Shanks	
9-3-102 C	5/8" - 2" dia., 1-3/8" depth
9-3-202 C	11/16" - 2-5/16" dia., 2" depth

One-Touch TCT cutters are available in the following sizes:

1-3/8" drill depth – \varnothing 5/8" to \varnothing 2"

2" drill depth – \varnothing 1/2" to \varnothing 2 3/4"

Every annular cutter includes a corresponding pilot pin.

• Metric cutters available on request

1-3/8" Depth

Order No.	Diameter
10-1-120 HC	5/8"
10-1-122 HC	11/16"
10-1-124 HC	3/4"
10-1-126 HC	13/16"
10-1-128 HC	7/8"
10-1-130 HC	15/16"
10-1-132 HC	1"
10-1-134 HC	1-1/16"
10-1-136 HC	1-1/8"
10-1-138 HC	1-3/16"
10-1-140 HC	1-1/4"
10-1-142 HC	1-5/16"
10-1-144 HC	1-3/8"
10-1-146 HC	1-7/16"
10-1-148 HC	1-1/2"
10-1-150 HC	1-9/16"
10-1-152 HC	1-5/8"
10-1-154 HC	1-11/16"
10-1-156 HC	1-3/4"
10-1-158 HC	1-13/16"
10-1-160 HC	1-7/8"
10-1-162 HC	1-15/16"
10-1-164 HC	2"

2" Depth

Order No.	Diameter	Order No.	Diameter
10-1-216 HC	1/2"	10-1-266 HC	2-1/16"
10-1-218 HC	9/16"	10-1-268 HC	2-1/8"
10-1-220 HC	5/8"	10-1-270 HC	2-3/16"
10-1-222 HC	11/16"	10-1-272 HC	2-1/4"
10-1-224 HC	3/4"	10-1-274 HC	2-5/16"
10-1-228 HC	7/8"	10-1-276 HC	2-3/8"
10-1-230 HC	15/16"	10-1-278 HC	2-7/16"
10-1-232 HC	1"	10-1-280 HC	2-1/2"
10-1-234 HC	1-1/16"	10-1-282 HC	2-5/8"
10-1-236 HC	1-1/8"	10-1-288 HC	2-3/4"
10-1-238 HC	1-3/16"		
10-1-240 HC	1-1/4"		
10-1-242 HC	1-5/16"		
10-1-244 HC	1-3/8"		
10-1-246 HC	1-7/16"		
10-1-248 HC	1-1/2"		
10-1-250 HC	1-9/16"		
10-1-252 HC	1-5/8"		
10-1-254 HC	1-11/16"		
10-1-256 HC	1-3/4"		
10-1-258 HC	1-13/16"		
10-1-260 HC	1-7/8"		
10-1-262 HC	1-15/16"		
10-1-264 HC	2"		

➤ See pages 42-50 for Drill Accessories.

Lubricants

Coolant extends the life of cutting tools

ProLube™ *Ideal for cutting steel, stainless steel and hard metals*



Your cutting tools will work cooler, longer and more efficiently with ProLube™ Lubricants from CS Unitec.

- Prolong tool life by reducing friction and wear
- Unique composition provides excellent adhesion to cutting tools for maximum lubrication
- Corrosion inhibitor
- Non-toxic

ProLube Paste
CS 7030-712
12 oz. tub

ProLube Liquid
Water soluble 16:1
CS 7010-504 - 1 gal. bottle

Upgrade your drill's cooling system: see page 44 for arbors with automatic cooling.

Cutting Oil

- High-performance, biodegradable, non-hazardous oils and pastes
- Oils for heavy removal of metal, including stainless steel
- Chlorine-free (MSDS on bottle/tub)
- Not necessary to dilute with water

Cutting Oil:
 Part No. **ZHS 006** (quart)
 Part No. **ZHS 005** (gallon)



Pressurized Coolant Bottle

Use with any automatic internal lubrication system.
 Part No. **9 4002 0020**

Pilot Pins for Cutters

- Milled channel efficiently supplies internal lubrication to cutting teeth
- Available for cutter diameters ranging from 7/16" to 5 1/8" and 1", 2", 3" and 4" depth of cut
- See price list for part numbers



*Shown at right:
 2-piece pin for
 3" and 4" depth
 cutters with
 8mm pilot hole
 (Part No. 7-3-402).*

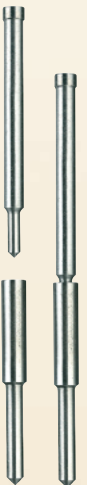

Accessories

Drill Chucks for Straight Shank Twist Drills

• Two capacities: 1/2" and 3/4"; four chucks and adapters to fit all magnetic drills

- A) **IBC 17** – 1/2" chuck for MAB 425 and CSU 32 series
- B) **IBC 18** – 1/2" chuck with 3/4" shank for MABasic 200, MABasic 400, MAB 3000 and AIRBOR™ (fits all drills with 3/4" arbor bore)
- C) **IBC 21** – 3/4" chuck with MT3 shank for MAB 825, MAB 845, CSU 80AC and CSU 100/3RL
- D) **IBC 22** – 3/4" chuck with MT2 shank for MABasic 450, MAB 455, MAB 485, MAB 525 and CSU 50 series

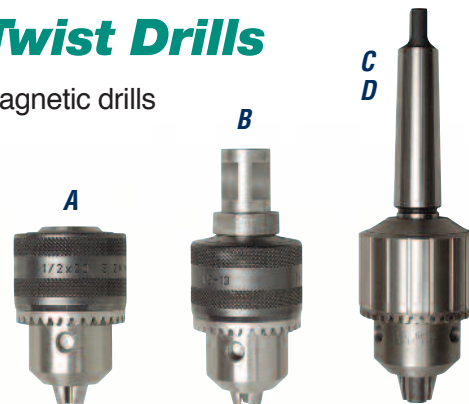

Quick-change Tapping Tools, Collets and Chucks



Tap Collets and Reducing Adapters

Tap Collets with 3/4" or 1-1/4" Weldon shank
all threads shown are ASA Standard (or DIN 376 for metric)

Thread	Order No.	Thread	Order No.
1/4	ZGA 1/4	9/16	ZGA 9/16
5/16	ZGA 5/16	5/8	ZGA 5/8
3/8	ZGA 3/8	11/16	ZGA 11/16
7/16	ZGA 7/16	3/4	ZGA 3/4
1/2	ZGA 1/2		

Bushing – Reduces 1-1/4" Weldon shank to 3/4" Weldon shank
Order No. **ZAP 200**



Reducing Sleeve
DIN 2185
Order No. **ZRH 430** for MT 4:3
(adapts MT4 to MT3)



Tap up to 1-5/8" max. dia.



See page 26 for additional tapping accessories.



Part No. **GSW-830C** tapping chuck includes two variable clamp collets to tap 3/8" to 1 1/8". It is the least expensive system if you will tap more than 4 sizes. **GSW-830C** has an MT3 connection. For use with all MT3 drills.

Variable clamp collets for use in tap chuck No. **GSW-830**:
Part No. **GST-160** variable clamp collet for shanks 3/8" – 5/8".
Part No. **GST-230** variable clamp collet for shanks 5/8" – 7/8".

Part No. **GSW-444** quick-change tapping chuck with MT4 connection (for MAB 1300). Collets not included.

- GSS-420** collet for 20mm shanks
- GSS-422** collet for 22mm shanks
- GSS-427** collet for 27mm shanks
- GSS-433** collet for 33mm shanks
- GSS-442** collet for 42mm shanks



Accessories

Arbors for Annular Cutters

- Use on any magnetic drill stand, drill press or shop equipment with a Morse Taper intake of No. 2, 3 or 4
- Available for Annular Cutter shank sizes of 3/4" or 1 1/4" Weldon
- Available for automatic internal cooling or manual cooling



Manual Cooling

- ZIA 219M** – Morse Taper No. 2
3/4" arbor bore
- ZIA 319M** – Morse Taper No. 3
3/4" arbor bore
- ZIA 30/75** – Morse Taper No. 3
3/4" arbor bore, 3" depth
- ZIA 419M** – Morse Taper No. 4
3/4" arbor bore
- ZIA 432KMN** – Morse Taper No. 4
1 1/4" arbor bore



Automatic Cooling

- ZIA 219KN** – Morse Taper No. 2
3/4" arbor bore
- ZIA 319KN** – Morse Taper No. 3
3/4" arbor bore
- ZIA 30/32** – Morse Taper No. 3
1 1/4" arbor bore

Quick-lock Arbor with Automatic Internal Cooling

- Keyless for fast, no-tools changeover for 3/4" dia. shank annular cutters
- Automatic internal cooling
- Turn, click... go!

ZSS 200 – Morse Taper No. 2 for 3/4" dia. shank annular cutters

ZSS 300 – Morse Taper No. 3 for 3/4" dia. shank annular cutters

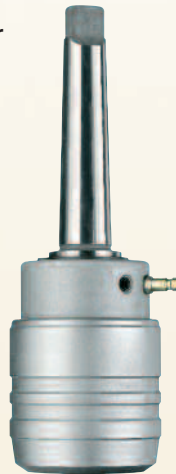

*turn,
click...*



*Keyless,
quick-change
system for annular
cutters saves time
and money.*

Just twist and lock!



Power Assist



The Power Assist is a standard capstan, designed with delayed torque transfer. This decreases the load on both cutter and drilling machine, allowing the machine to maintain max. RPM under full load.

- Reduces drilling time
- Prevents cutter breakage
- Extends lifespan of cutter/drill bit and machine

ZPA 401 – Power Assist for CSU 32 and CSU 50 series
ZPA 402 – Power Assist for CSU 80 and CSU 100/3 series



Power Assist Capstan

Accessories

Extensions for Annular Cutters

Extra-long holders extend stroke of drills



- Extend cutter reach up to 18"
- Available for magnetic drills with 3/4" arbor bore or MT3
- Also available with 3 flats for straight shank drill chucks and R8 shanks for drill presses
- Drill difficult-to-reach areas
- Extend cutter reach over the side or through an existing hole*

- 7-9-902** – 2" extension
- 7-9-903** – 3" extension
- 7-9-906** – 6" extension
- 7-9-912** – 12" extension
- 7-9-918** – 18" extension

* Hole diameter must be larger than 1 5/16" to accommodate width of extension



We also offer extensions with the following connections:

3 Flats for Geared Chucks x 3/4" arbor



- 7-9-100** – 2-1/8" length, 1/2" shank
- 7-9-200** – 2" length, 3/4" shank

R8



- 7-9-500** – R8, 1-3/4" length; 3/4" arbor bore
- 7-9-506** – R8, 6" length; 3/4" arbor bore
- 7-9-70C** – R8, 2-3/4" length; 1-1/4" arbor bore

2-in-1 Drill/Taps Drill and tap with one tool

National Coarse Threads (UNC) – sizes available:

- CS500** – 1/2" x 13 UNC
- CS625** – 5/8" x 11 UNC
- CS750** – 3/4" x 10 UNC
- CS875** – 7/8" x 9 UNC
- CS1000** – 1" x 8 UNC
- CSDT-UNCKIT** – 1/2", 5/8", 3/4" & 1" drill/taps



82° and 90° Countersinks

- Manufactured of HSS with 5% cobalt
- 3/4" Weldon shank

Countersink hole sizes:

- CTS 30** from 5/8" to 2" / 82°
- CTS 50** from 5/8" to 2 1/8" / 90°



Detachable Chip Guard Protects against flying chips when drilling

ZSS 050 – for MAB 150, MAB 425, MAB 485 and MAB 525

Accessories

Starter Kits

CS Unitec starter kits offer the essentials you need to begin drilling. We have two options that provide a cost-effective tool set for your application.



HSS Steel Cutter Starter Kit

ZST 100S Kit Includes:

Set of 5 annular cutters (one each of the following):

- 9/16" dia. x 1" depth (6-1-118)
- 11/16" dia. x 1" depth (6-1-122)
- 13/16" dia. x 1" depth (6-1-126)
- 15/16" dia. x 1" depth (6-1-130)
- 1-1/16" dia. x 1" depth (6-1-134)

2 pilot pins • 1 cutter storage box • 1 Power Worker magnetic stick (POW 100)
1 quart high-performance cutting oil (ZHS 006)

See pages 34-35 for more information on HSS annular cutters.



Armor-Plated TiAlN Cutter Starter Kit

ZST 100P Kit Includes:

Set of 5 annular cutters (one each of the following):

- 9/16" dia. x 1" depth (8-1-118)
- 11/16" dia. x 1" depth (8-1-122)
- 13/16" dia. x 1" depth (8-1-126)
- 15/16" dia. x 1" depth (8-1-130)
- 1-1/16" dia. x 1" depth (8-1-134)

2 pilot pins • 1 cutter storage box • 1 Power Worker magnetic stick (POW 100)
1 quart high-performance cutting oil (ZHS 006)

See pages 36-37 for more information on Armor-Plated TiAlN annular cutters.

Other annular cutter kits are available – contact CS Unitec for details.



Power Worker – simple cleanup of steel chips

Rare earth magnet cleans metal parts and shavings



POW 100



- Easily clean up sharp-edged drill chips, screws and other metal parts
- Items are safely ejected off of Power Worker without hand contact
- Ideal for hard-to-reach spaces

Clamping Devices

MOBIL CLAMP

**A true advance in magnetic drilling technology:
The new clamping system MOBIL CLAMP can be used to
convert a magnetic drilling machine into a bench drill.**

Extends the functionality of your portable magnetic drill. Ideal for parts that previously could only be drilled in the workshop – they can now be machined on site. MOBIL CLAMP makes it possible to drill, countersink, ream or tap small parts, since these can be mounted into the quick clamping device.

With the mounting of a magnetic drilling machine onto the surface of the vice and the subsequent activation of the magnet, you will have a versatile, stationary drilling machine in next to no time. The magnetic drilling machine becomes a multi-purpose machine: whether large or small applications, flat or high, with the twist drill or the reamer, everything is possible. A stable support, designed for the MOBIL CLAMP clamping device, ensures the correct working height and a comfortable and reliable operation.

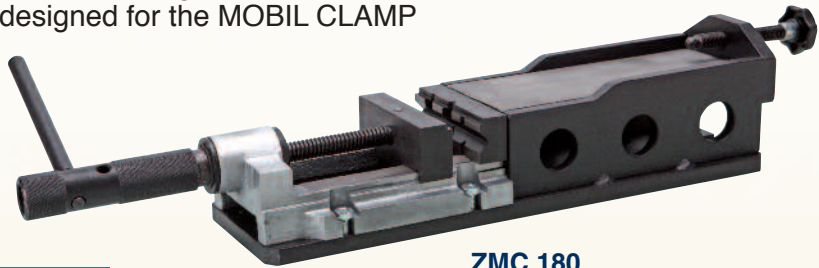

ZMC 180

MOBIL CLAMP

Order No.	Jaw width	Quick-action clamping jaw	V-block clamping jaw
ZMC 180	4" (100mm)	3.15" (80mm) clamping width	•
ZMC 300	Base stand for clamping device		

Powerful grip

Jaws with step and prism for clamping of flat and round material.

Fine adjustment

in longitudinal movement by an adjusting screw accurately set to the machining point.

ZMC 300

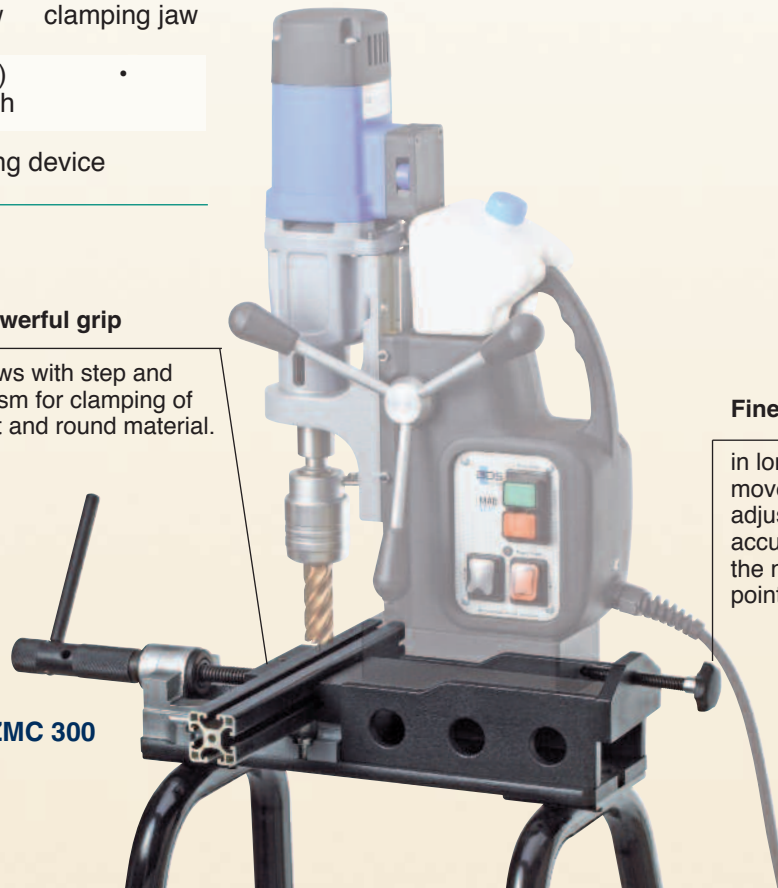

Clamping Devices

Drilling stand and vise for hand drills

Industrial drilling pillars for commercial hand drills with 43mm chuck journal diameter.
 Optimum stability by cast base plate combined with a pillar top of the MAB series.
 Versatile usability by a drill vise with 4" (100mm) jaw width (special accessories).
 Screws for slots are available for additional security under higher loads (special accessories).
 Working stroke of 9" - 17" (230 - 425mm).



Drilling Pillar

Order No. **ZBS 100**

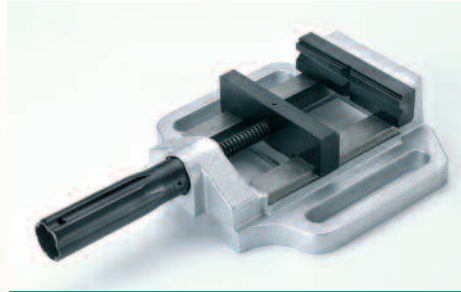

Vise

Order No. **ZST 300**
 jaw width: 4" (100mm)
 clamping range: 4" (100mm)

Accessories

Screws for T-Slots
 Order No. **ZTN 100**

Hexagon Nut with Collar
 Order No. **ZSM 100**

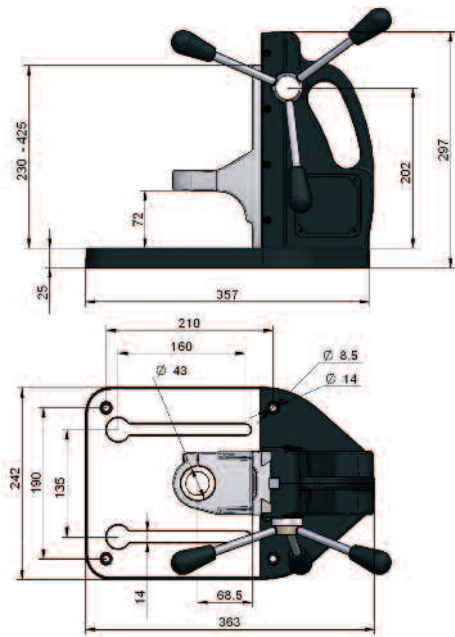

Dimensions shown in mm.



Drill not included.

Vacuum Plates

For applications where drill alone will not adhere to surface

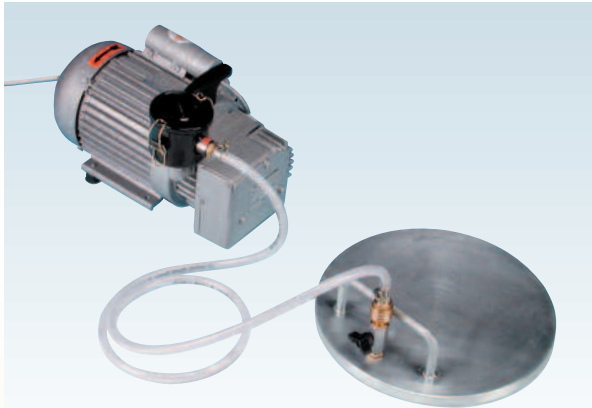

Vacuum Plate for Channeled Plates

Order No. **ZAV 301** (vacuum plate only)

Order No. **ZAV 310** (vacuum plate and vacuum pump, 110V)

Ideal for channeled plates. High-performance vacuum pump with circular oil lubrication. Clamping plate diameter: 11.8"



Vacuum Plate for Smooth Surfaces

Order No. **ZAV 401** (vacuum plate only)

Order No. **ZAV 410** (vacuum plate and vacuum pump, 110V)

Ideal for smooth surfaces. High-performance vacuum pump with circular oil lubrication. Clamping plates with two suction surfaces and cut-through drilling area.



Pipe Saddle Clamp System

Ensures safe, secure drilling of pipes and tubular material

PIPE SADDLE CLAMP

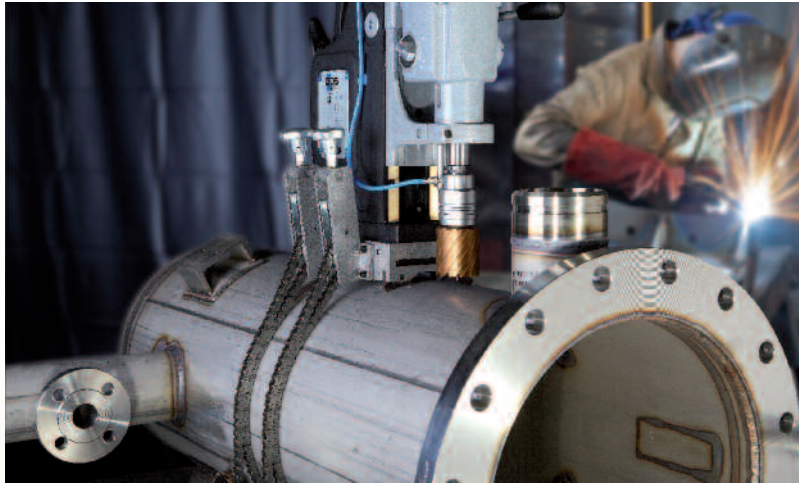

Ideal for applications requiring the flexibility of clamping on pipes from 3-1/4" to 20" diameter, these pipe clamp systems are flexible and easy-to-use. Swivelling V-blocks fit the contour of the pipe while the heavy-duty tension chains securely affix the clamps to the piece being drilled. The drilling chains position can be easily and safely adjusted.

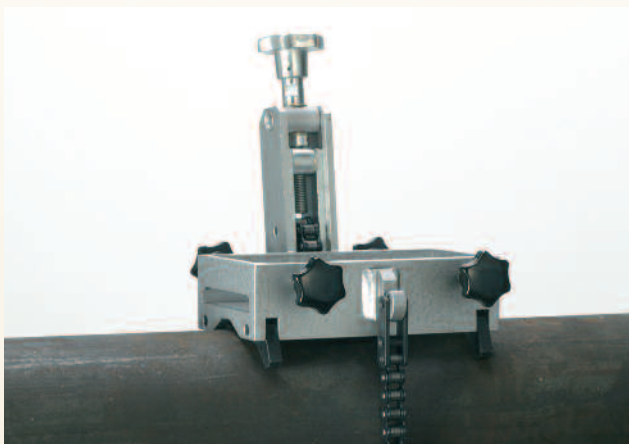

ZRO 250 Pipe Saddle Clamp System

Pipe diameters 3¹/₄" - 10"
Chain length: 35¹/₂"
For models: MABasic 200, MABasic 400, MABasic 450, MAB 455, MAB 485, MDM 40 and CSU 32



ZRO 500 Pipe Saddle Clamp System

Pipe diameters 6" - 20" (extension chain available)
Chain length: 65"
For models: MAB 525, MAB 825, MAB 845, CSU 50, CSU 80, CSU 100/3, AB-4300-2 and HB 4400

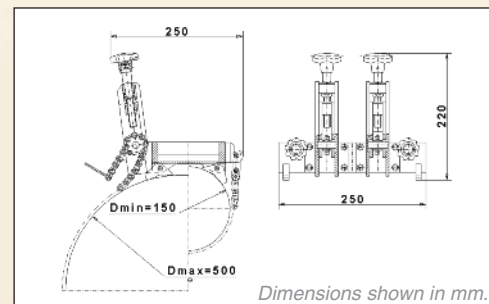
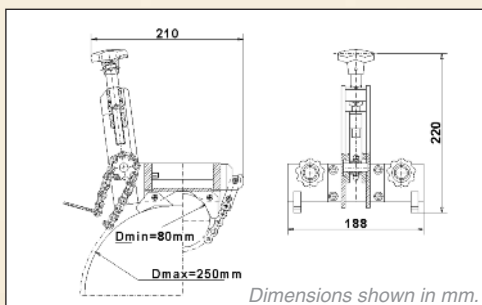

Order No. **ZRO 001** – extension chain for ZRO 500 pipe saddle clamp.

Custom-engineered Machines

Design a custom machine for your specific needs

Unusual applications require unique solutions. We can help you build custom drills for a wide variety of applications. With our considerable experience building custom drills, our engineers can assist you to create machines that can drill on uneven surfaces, in various directions, and more.

We enjoy a challenge! Contact us today for a professional solution for your unique application. Our capabilities include:

- In-house CAD design
- Prototype construction
- Manufacturing of special accessories

Custom Machine Options Include:

- ✓ **Reverse Drilling**
- ✓ **Alternative Mounting Configurations**
- ✓ **Magnet Variations**
- ✓ **Motor Customization**
- ✓ **Adjustable Drilling Depth**

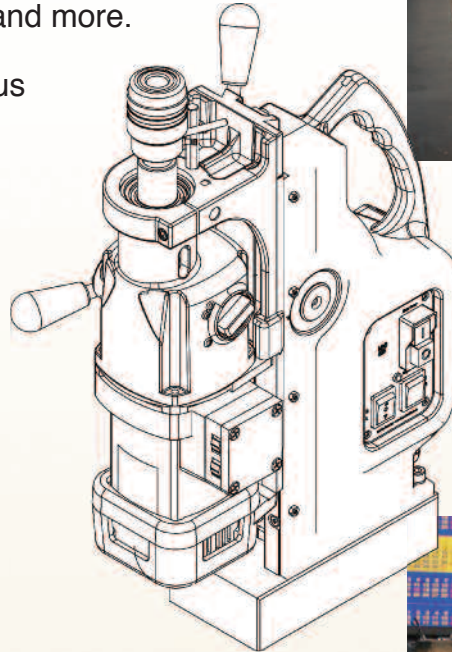

Machine rendering above shows reverse-mount motor for drilling upside down.

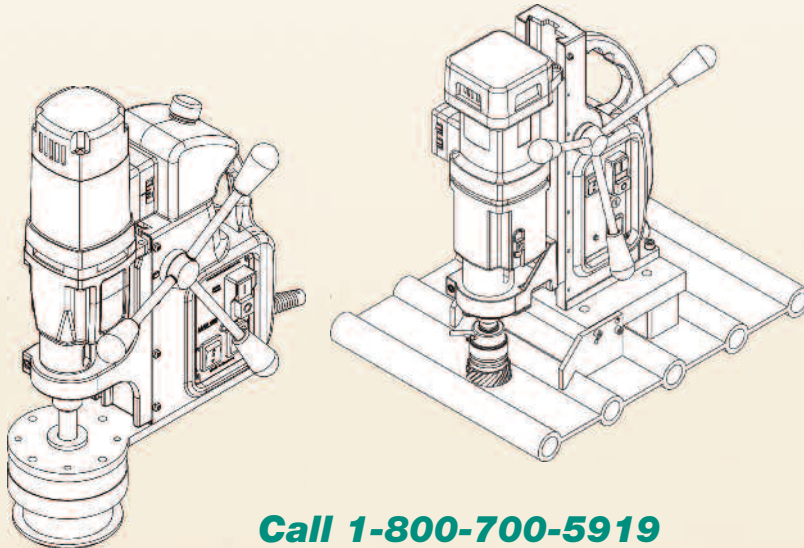

**Call 1-800-700-5919
for design assistance.**

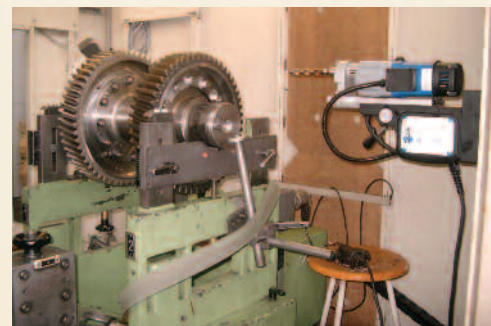
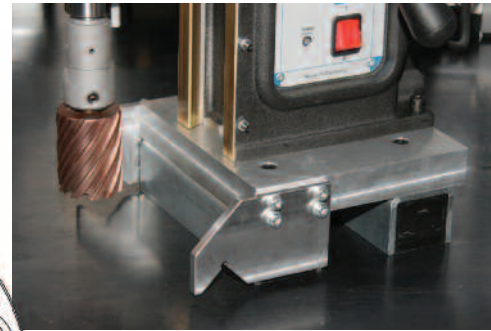

Multi-purpose Beveling Machine

Bevel, deburr & chamfer edges of steel plate faster and cleaner than angle grinders

The EKF multi-purpose beveling machine is designed to bevel 30° or 45° weld seams on steel, stainless steel, nonferrous metals, brass and plastics. It can also be used to deburr and chamfer; straighten edges, internal and external radii; and countersink holes from 7/8" diameter.

- Fine adjustment feature for slight chamfers when deburring for the preparation of weld seams
- Four milling head options – 30°, 45°, 0.063" (1.6mm) and 0.098" (2.5mm) radius inserts available
- Ideal for the following applications: **Moldmaking** (straighten edges, internal and external radii and countersink holes from 7/8" dia.); **Boiler and process plant construction** (prepare weld seams on heat exchangers); **Mechanical engineering** (deburr machine parts, chamfer edges to protect against paint peeling and create visible edges); **Sheet metal** (deburr cut edges)

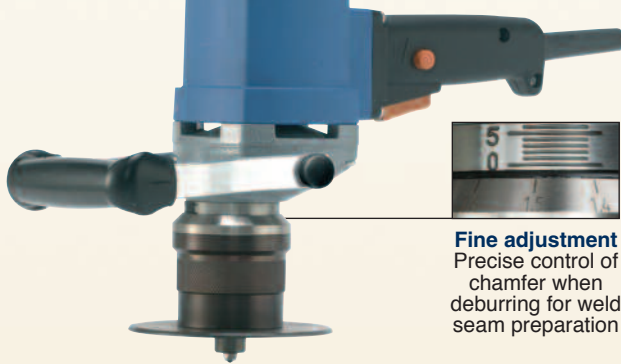

Fine adjustment
Precise control of chamfer when deburring for weld seam preparation



Portable Beveler Specifications

	EKF300.3	EKF450.3	EKF452.3
Beveling angle*	30°	45°	0.098" (2.5mm)
Bevel width (max.)**	1/4"	1/4"	1/4"
Motor power/Voltage	13.5 Amp / 110 V (220 V / 50 Hz also available)		
Cutting speed	3000 SFPM		
Cutting inserts	3		
Dimensions (L x W x H)	12-1/2" x 5-1/2" x 11-5/8"		
Weight	10.5 lbs.		

* EKF milling heads are interchangeable.

** Max. bevel width may require several passes, depending on material hardness.

One Machine, Three Milling Options

30°  EKF300.3 Milling cutter 30°, Chamfer 0 - 1/4"	45°  EKF450.3 Milling cutter 45°, Chamfer 0 - 1/4"	Radius  0.063" (1.6mm) 0.098" (2.5mm)
--	---	---

Cutting Inserts - Sold as pack of 10
 Order No. **SHM 200**: 30° and 45°
 Order No. **SHM 200-E**: 30° and 45° for stainless steel
 Order No. **SHM 201**: 1.6mm radius (0.063")
 Order No. **SHM 202**: 2.5mm radius (0.098")

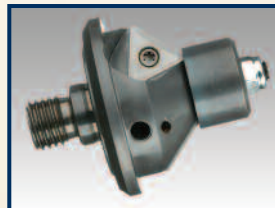

Standard equipment includes milling head and three inserts, SW22 key, carrying case and user's manual. Please see our Price List for available accessories.

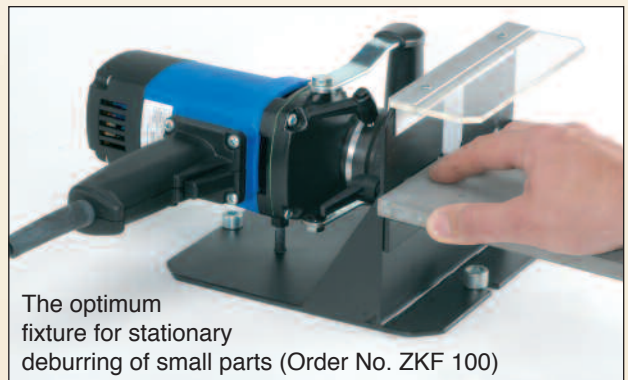

The optimum fixture for stationary deburring of small parts (Order No. ZKF 100)

Portable Beveling Machine

Bevel angles from 15° to 60° on plate and pipes

CS Unitec's SKF 25 Beveling Machine provides fast and easy preparation of weld seams and bevels 15° to 60° angles on plate or pipe. It is ideal for use on steel, stainless steel, aluminum and nonferrous metals and offers high-quality performance that allows for superior weld connections.

- Continuously adjustable angle (15° to 60°) and land width up to 3/4"
- Robust design, single operator control and easy handling; designed for continuous operation with smooth roller guides
- Anti-vibration system protects electronics and allows for more comfortable operation
- Includes one milling head and 10 indexable inserts for fast metal removal and extended tool life
- Work on welding angles and weld preparation on pipes/tubes with a minimum OD of 6-1/4" (160mm) with built-in pipe roller guide; ideal for beveling pipe 6-1/4" OD and larger



SKF 25

Portable Beveler Specifications

SKF 25	
Beveling angle	15° - 60°
Bevel width (max.)**	3/4"
Motor power	16 Amp
Voltage	110 V (220 V / 50 Hz also available)
Cutting speed	1800 SFPM
Cutting inserts	10
Dimensions (L x W x H)	16-1/2" x 13"
Weight	43 lbs.

** Max. bevel width may require several passes, depending on material hardness. Steel case intended mainly for shipping purposes; damage may occur in transit.

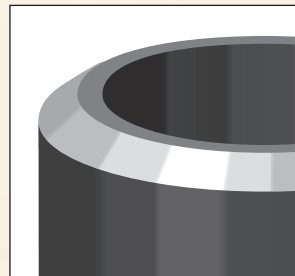

Single-operator, straightforward handling

Precise roller guidance, low friction resistance

Ideal for beveling pipe 6.25" OD and larger

Cutting Plates - Sold as pack of 20
Order No. **SHM 800**; for beveling carbon and stainless steel

Standard equipment includes one milling head, 10 sintered carbide reversible cutting inserts, tools for assembly, built-in pipe roller guide, steel carrying case and user's manual. Please see our Price List for available accessories.

Self-Guiding Beveling Machine

Powerful, automatic edge processing machine for 15° to 60° edges on plate up to 1-1/2" thick



CS Unitec's AutoCUT 500 Self-Propelled Beveling Machine provides fast and easy preparation of weld seams and bevels 15° to 60° angles on plate up to 1-1/2" thick. The unit propels itself on the plate – both forward and backward – without the need for a cart or stand. It is ideal for use on steel, aluminum and nonferrous metals and offers high-quality performance that allows for superior weld connections.

- Continuously adjustable angle (15° to 60°) and land width up to 1-3/16"
- Robust design, single operator control and easy handling
- Automatic feed on plate without the need for a cart or stand
- Includes one milling head and 6 indexable inserts for fast metal removal and extended tool life

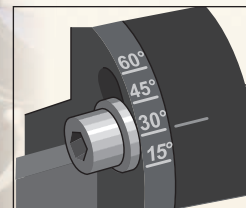
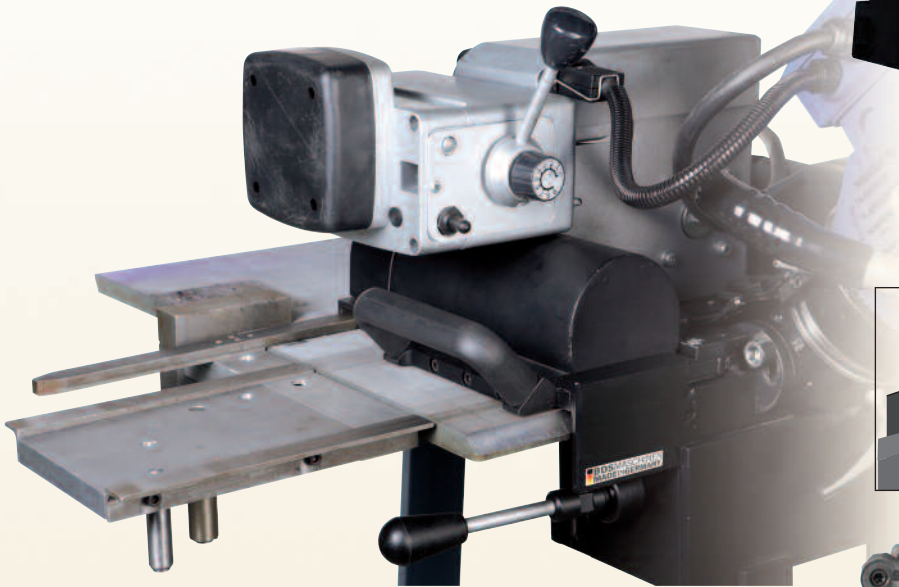
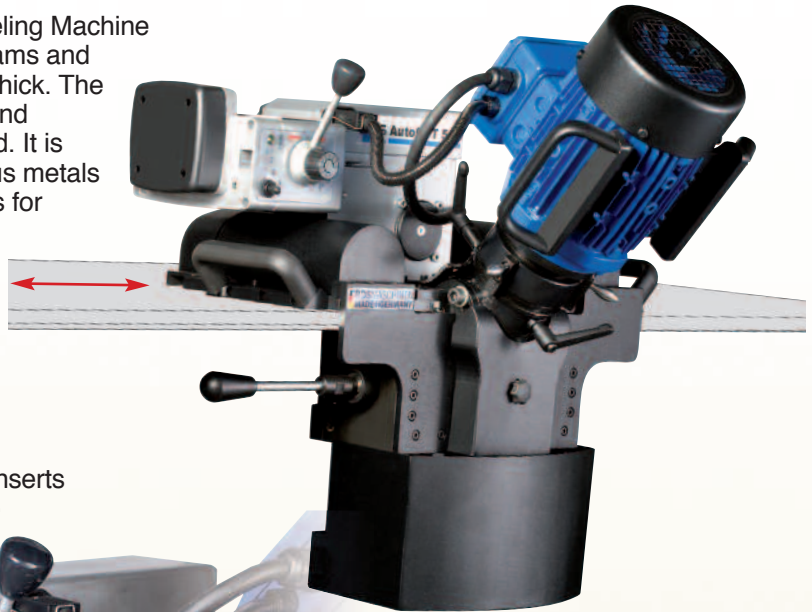

Continuously Adjustable Beveling Angle

Bevel 15° to 60° angles and land width up to 1-3/16" on plate up to 1-1/2" thick.



Reversible Carbide Cutting Inserts

Round inserts provide more useable edges per inserts

Portable Beveler Specifications

AutoCUT 500	
Beveling angle	15° - 60°
Bevel width (max.)**	1-3/16"
Motor power	10 Amp
Voltage	230 V, 3-phase
Cutting speed	2750 SFPM
Cutting inserts	6
Dimensions (L x W x H)	23-1/2" L x 24" W x 20-1/2" H
Weight	110 lbs.

** Max. bevel width may require several passes, depending on material hardness.

Cutting Plates - Sold as pack of 20
 Order No. SHM 400: for beveling carbon and stainless steel

Standard equipment includes one milling head, 6 sintered carbide reversible cutting inserts, 1 jaw spanner (M 19), 1 t-handle screwdriver (WS 5), 1 offset screwdriver (WS 6, 8 & 10), 1 screwdriver (TX 15), 1 inlet rail, 1 outlet rail, carrying case and user's manual. Please see our Price List for available accessories.

Sheet Metal Deburring Machine

Double-sided deburring of sheet metal up to 0.2" thick in one pass – with no additional treatment

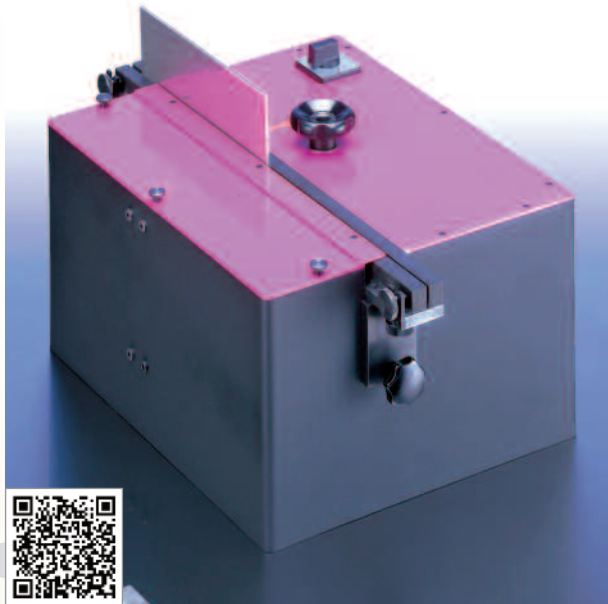

Double-sided deburring of sheet metal up to 0.2" thick can be achieved in a single operation with no additional treatment. The machine's flap wheels can be easily adjusted as they wear. One set of wheels lasts for approximately 6500 feet of stainless steel sheet. Supplied standard with two 80 grit flap wheels, the ROLEI® BE 5 can be used with other optional grits to suit the facet width and materials of your particular application.

Features two-speed operation:

- Speed 1: fine deburring, 600 RPM
- Speed 2: standard deburring, 1200 RPM

Optional accessories:

- Spare flap wheels (40, 60, 80, and 120 grit)
- Machine stand, made from strong steel
- Port for industrial dust extractor (part no. 30330)

Can also be used on its side with roller tables for large thin sheets.

ROLEI BE 5 Specifications

**Order Number: 30310A (220 Volt)
30310 (380 Volt)**

3-phase motor 220 - 240 V 3-phase / 2 speeds
.2 KW / .9 Amp
400 - 440 V 3-phase / 2 speeds
.2 KW / .45 Amp

Dimensions 19.7" x 12.8" x 7.9"

Weight 64 lbs.

Options Machine stand, dust extractor connection port, teflon tape

ROLEI BE 5 Flap Wheels

Part No.	Grit	Qty.
37040	40	2 discs per pack
37060	60	2 discs per pack
37080	80	2 discs per pack
37120	120	2 discs per pack

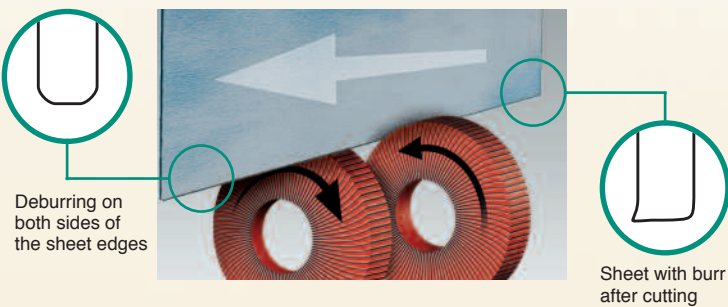
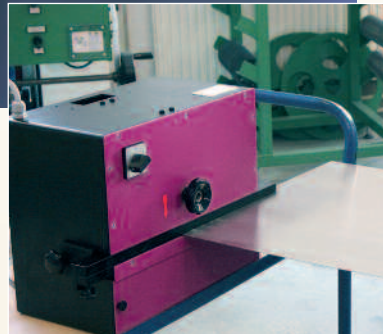

Spare flap wheels for sheet metal deburring machine BE 5
Grit 40, 60, 80, 120



Machine stand - P/N: 30320
Strong steel machine stand with black powder coating



Dust extraction port (end and bottom views shown above)
P/N: 30330



Teflon protective tape - self-adhesive (2 required)
P/N: 30340 (19.75" length x 3/4" width)
P/N: 30341 (27.5" length x 3/4" width)
For extension rail to protect from scratching the workpiece

Carbide-Tipped Hole Saws

CARBIDE-TIPPED HOLE SAWS



Cut holes in steel plate up to 3/8" thick



Model EHB 16/2.4 SR/LC: 2-speed, variable-speed drill with safety clutch

- Tungsten carbide-tipped cutting edges last longer and can be run at higher feeds and speeds to create holes of exceptional quality and accuracy
- One-piece construction; diameters from 9/16" to 4-1/2"
- Designed for use with hand-held drills – recommended drills include our EHB 16 series or other hand-held drills with slip clutch – see page 57



1-Series Carbide-Tipped Hole Cutters

1" effective length
Center twist pilot drill
Safety Collar Stop

3/8" shank on cutters up to 3-1/4" dia.
1/2" shank on cutters 3-5/16" dia. and larger

2-Series Carbide-Tipped Hole Cutters Extra Heavy Duty

9/16" effective length
Spring-loaded Pilot Pin

Cutters feature milled, 3-flat shank designed to fit 1/2" chucks.



Order No.	Diameter
1-1-118	9/16"
1-1-120	5/8"
1-1-122	11/16"
1-1-124	3/4"
1-1-126	13/16"
1-1-128	7/8"
1-1-130	15/16"
1-1-132	1"
1-1-134	1-1/16"
1-1-136	1-1/8"
1-1-138	1-3/8"
1-1-140	1-1/4"
1-1-142	1-5/16"
1-1-144	1-3/8"
1-1-146	1-7/16"
1-1-148	1-1/2"
1-1-150	1-9/16"
1-1-152	1-5/8"
1-1-154	1-11/16"

Order No.	Diameter
1-1-156	1-3/4"
1-1-158	1-13/16"
1-1-160	1-7/8"
1-1-162	1-15/16"
1-1-164	2"
1-1-166	2-1/16"
1-1-168	2-1/8"
1-1-170	2-3/16"
1-1-172	2-1/4"
1-1-174	2-5/16"
1-1-176	2-3/8"
1-1-178	2-7/16"
1-1-180	2-1/2"
1-1-182	2-9/16"
1-1-184	2-5/8"
1-1-186	2-11/16"
1-1-188	2-3/4"
1-1-190	2-13/16"
1-1-192	2-7/8"

Order No.	Diameter
1-1-194	2-15/16"
1-1-196	3"
1-1-198	3-1/16"
1-1-1100	3-1/8"
1-1-1102	3-3/16"
1-1-1104	3-1/4"
1-1-1106	3-5/16"
1-1-1108	3-3/8"
1-1-1110	3-7/16"
1-1-1112	3-1/2"
1-1-1114	3-9/16"
1-1-1116	3-5/8"
1-1-1118	3-11/16"
1-1-1120	3-3/4"
1-1-1122	3-13/16"
1-1-1124	3-7/8"
1-1-1126	3-15/16"
1-1-1128	4"
1-1-1136	4-1/4"
1-1-1144	4-1/2"

Order No.	Diameter
2-1-118	9/16"
2-1-120	5/8"
2-1-122	11/16"
2-1-124	3/4"
2-1-126	13/16"
2-1-128	7/8"
2-1-130	15/16"
2-1-132	1"
2-1-134	1-1/16"
2-1-136	1-1/8"
2-1-138	1-3/16"
2-1-140	1-1/4"
2-1-142	1-5/16"
2-1-144	1-3/8"

2-Series Accessories

Order No.	Description
2-1-pilot	Pilot/Ejector Pin
2-1-screw	Screw

1-Series Accessories

Order No.	Description
1-1-drill	Center Pilot Drill
1-1-spring	Spring
1-1-screw	Screw

Electric Drills and Drive Units

High-torque, multi-gearred and variable-speed motors



Model EHB 16/2.4 S
Model EHB 16/2.4 SR/LC



Model EHB 20/2.4



Model EHB 32/4.2



Model EHB 16/1.4 S



Model EAU 34/4 CB

Model EAU 36/4 R R/L

Heavy-duty Drills for Industry and Construction:

- High-torque output
- Variable-speed, two- and four-gearred drills for optimum speed selection
- Reversible motors and electronic torque control on selected models
- Ideal for special applications including valve turning, tube rolling and other jobs
- Safety slip clutch on 1¹/₄" capacities to protect operator and tool
- Drilling capacities up to 1¹/₄" in steel
- Special OEM motors available on request
- One-year warranty



Model No.	Motor Power (Amps)	Voltage*	Load Speed (RPM)	Drilling Capacity in Steel	Max. Torque Output (ft./lbs.)	Reversible	Chuck/Arbor	Weight (lbs.)
EHB 16/1.4 S	7.3	110V	0-500	5/8"	12	NO	5/8" Keyless	6.8
EHB 16/1.4 S R/L	9.6	110V	0-450	5/8"	19	YES	5/8" Keyless	7
EHB 16/2.4 SR/LC	10	110V	0-430/0-760	5/8"	19	YES	5/8" Geared	7
EAW 16/2 R/L	9	110V	510/950	N/A	8	YES	5/8" X 16 UN	7
EHB 20/2.4	10.5	110V	250/450	3/4"	32	NO	MT2	9.2
EHB 32/4.2	15.5	110V	110/175/245/385	1 ¹ / ₄ "	112	NO	MT3	15.2
EAU 34/4**	20	110V	80/130/360/570	–	203	YES	MT3	19.5
EAU 36/4 R R/L† with 4-speed gearbox and variable speed	22	110V	50-120 80-190 110-270 180-420	–	187	YES	MT3	20

* All units available in 220 Volt / 50Hz ** EAU 34/4 available with control box (on/off, reverse) – order Model. No. EAU 34/4 CB

† EAU 36/4 R R/L available with control box – order Model. No. EAU 36/4 R R/L CB Special Motors available upon request.

Electric Drills and Drive Units

Slow Speed: two-gearred, variable-speed reversible motors



Model ETE 32/2.3 R/RL
(shown with optional Square Drive adapter)

- High-torque, two-gearred and variable-speed reversible motors
- Ideal for drilling, reaming and tapping steel
- Driving applications include mills, spindles, bar boring, pipe beveling and valve turning
- Perfect for tube rolling and expanding for fire tube and water tube boilers
- Mechanical safety clutch prevents operator injury or damage to the tool
- Morse Taper #3 arbor
- One-year warranty



Model EHB 32/2.2 R/RL
Model ETE 32/2.3 R/RL



Up to 1 1/4" twist drill capacity

1/2" and 3/4" Square Drive accessories allow motor compatibility for various drive applications.*



Model No.	Motor Power (Amps)	Voltage**	Load Speed (RPM)	Drilling Cap. in Steel	Tube Rolling (max.)	Reversible	Torque Output (ft./lbs.)	Torque Control	Arbor	Weight (lbs.)
EHB 32/2.2 R/RL	16.3	110V	60-140 / 200-470	1 1/4"	2"	YES	92 max.	YES	MT3	14
ETE 32/2.3 R/RL	16.3	110V	30-75 / 90-230	N/A	3" ***	YES	174 max.	NO	MT3	15

** All units available in 220 Volt / 50Hz
*** With Expander (Up to 2 1/2" with Bead Roller)

* 1/2" Square Drive with MT3 – Part No. 830-1230-050
3/4" Square Drive with MT3 – Part No. 830-1230-075

Special Electric Motor Options

High-torque, reversible electric drill motors for custom applications

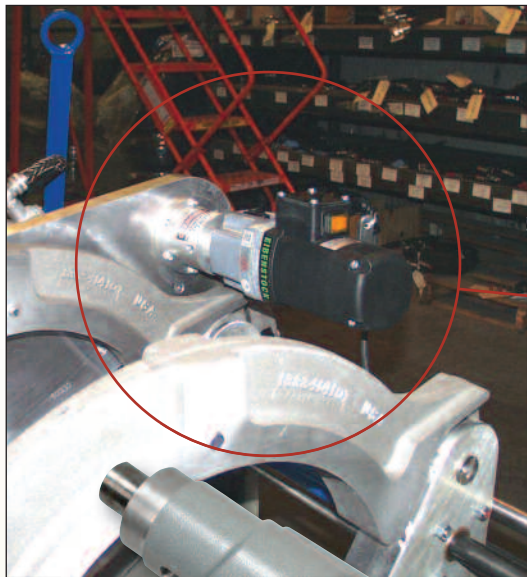

Control Boxes with On/Off, Variable Speed

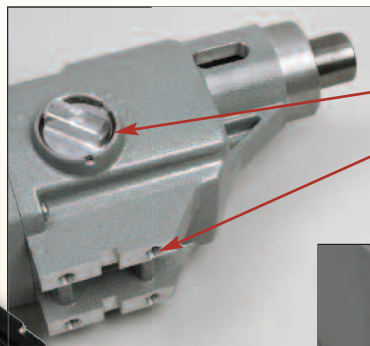

*Gear Selection Knob
Holes for Mounting
(Model EAU 34/4 only)*

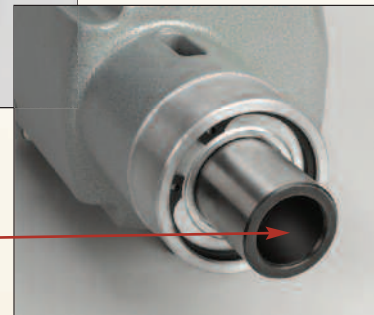

*Spindle Options:
MT2 / MT3
Square Drive
or Threaded*

Driving applications include mills, spindles, bar boring, tube rolling, valve turning and more.

Custom Design Options Include:

- ✓ **Forward/Reverse**
- ✓ **Variable Speeds**
- ✓ **Multiple Gears**
- ✓ **Spindle: MT or Special**
- ✓ **Multifunctional Control Boxes or Handles**
- ✓ **1/2 to 4 HP**
- ✓ **Modular Design**

Contact us today to configure the motor that meets your specific driving applications.



*Forward/Reverse Control
Electronic Torque Control
Variable-speed Dial*

Pneumatic Drills and Drive Units

High-torque reversible drilling and tapping machines



- High-torque reversible drilling, tapping and threading machines
- Ideal for drilling, reaming, tube rolling, tube expanding and tapping
- Use for special applications including mills, spindles, slides, controllers, pipe tapping, valve turning and more
- Drill chucks and Morse Taper arbors
- Hammer drills for drilling concrete with up to 2200 blows per minute
- Special OEM air motors available on request
- One-year warranty

D-handle Drills



Model 2 1310 0010

Morse Taper Drills w/ Feed Spindle



Model 2 2089 0030 with reverse and safety twist throttle



See page 62 for Rotary Hammer Drills

Pneumatic Hammer Drills



Model 2 1266 0010

Pneumatic Pistol Drills

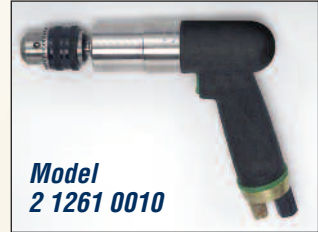

Model 2 1261 0010

Model No.	Motor Power (HP)	Load Speed (RPM)	Reversible	Chuck/ Arbor	Drilling Cap. in Steel	Tube Rolling Cap.	Torque Output (ft./lbs)	CFM at 90 PSI	Length	Feed Length	Weight (lbs.)
Pistol Drills											
2 1261 0010	0.7	850	NO	1/2" Chuck	1/2"	N/A	7 max.	21	9 ³ / ₄ "	N/A	4.6
Hammer Drills (for concrete and underwater applications)											
2 1266 0010	0.75	950	NO	1/2" Chuck	1/2"	N/A	7 max.	21	12"	N/A	6.7
D-handle Drills											
2 1310 0010	0.8	650	NO	1/2" Chuck	1/2"	N/A	8 max.	24	12 ¹ / ₂ "	N/A	12
2 1311 0010	0.8	650	NO	MT1	5/8"	N/A	8 max.	24	11"	N/A	12
Morse Taper Drills w/ Feed Spindle											
2 2089*	1.7	250	YES	MT3	1 ¹ / ₄ "	1"	36 max.	24	26 ¹ / ₂ "	1 ⁵ / ₈ "	28
2 2506*	2.5	220	YES	MT3	1 ¹ / ₄ "	2"	63 max.	70	26 ¹ / ₂ "	2 ¹ / ₂ "	32
2 2502*	2.5	80	YES	MT4	2"	2 ¹ / ₂ "	173 max.	70	26 ¹ / ₂ "	2 ¹ / ₂ "	37

* The last four digits of the Model No. identify the type of throttle. Please specify the four digits when ordering: 0010 for Lever Throttle or 0030 for Safety Twist Throttle.

Pneumatic, electric and hydraulic: high-torque drilling, reaming and driving units



Model 2 1801 0030

Corner Drills and Bridge Reamers

- Small side-to-side distance for tight spaces
- Self-closing roll throttle
- Built-in oiler for motor
- Ideal for bridge reaming and drilling applications
- One-year warranty
- Visit www.csunitec.com for dimensions



Slow-speed, High-torque Straight Drive Units



Model 2 2087 0010 with reverse and lever throttle

- Ideal for heavy-duty reaming, tube expanding and tapping
- Perfect for special driving applications, including pipe tapping and valve turning

Square Drive Accessories

- 2 2089 7020 – 7/8" Male Sq. Drive to 3/4" Male Sq. Drive
- 2 2089 7070 – 7/8" Male Sq. Drive to 1" Male Sq. Drive
- 6 1016 7940 – 7/8" Male Sq. Drive to 1" Male Sq. Drive with retaining pin

Pneumatic Corner Drill Model No.	Morse Taper	Drilling (in steel)	Reaming (in steel)	Tube Rolling Cap.	Torque Output (ft./lbs.)	Load Speed (RPM)	Motor Power (HP)	CFM at 90 PSI	Length	Weight (lbs.)
Nonreversible										
2 1602 0030	#1	5/8"	1/2"	N/A	7	500	0.7	21	12.5"	7
2 1701 0030	#2	7/8"	5/8"	N/A	35	270	1.8	49	20.9"	19
2 1801 0030	#3	1 1/4"	1"	N/A	53	260	2.6	63	22.5"	25
Reversible										
2 2104 0030	#4	2 1/8"	2"	2"	86	180	3.0	71	23.8"	37

Model No. 2 1602 0030 has a 3/8" NPT air inlet. 1/2" (13mm) hose is recommended. All other models have 3/4" NPT air inlet. A 1/2" (13mm) hose is recommended for model 2 1701 0030. A 5/8" (15mm) hose is recommended for models 2 1801 0030 and 2 2104 0030.

Hydraulic Corner Drill Model No.	Morse Taper	Drilling (in steel)	Reaming (in steel)	Tube Rolling Cap.	Torque Output (ft./lbs.)	Load Speed (RPM)	Motor Power (HP)	Oil Flow/PSI	Length	Weight (lbs.)
2 1806 0010	#3	1 1/4"	1"	N/A	60	220	3.8	4 GPM @2000	21"	25

Electric Drill Model No.	Motor Power (Amps)	Voltage	Load Speed (RPM)	Drilling Cap. in Steel	Tube Rolling (max.)	Reversible	Torque Output (ft./lbs.)	Torque Control	Arbor	Weight (lbs.)
EHB 32/2.2 R/RL	16.3	110	60-140 200-470	1 1/4"	2"	Yes	92 max.	Yes	MT3	14

Pneumatic Drive Unit Model No.	Square Drive ID	Torque Output (ft./lbs.)	Load Speed (RPM)	Reversible	Tube Rolling Cap.	Tapping Cap.	Motor Power (HP)	CFM at 90 PSI	Height x Length	Weight (lbs.)
2 2081*	13/16"	413	20	YES	3"	1 1/2"	1.35	53	10.9" x 26.5"	29
2 2087*†	7/8"	413	20	YES	3"	1 1/2"	1.35	53	10.9" x 26.5"	29
2 2088*†	7/8"	138	60	YES	2"	3/4"	1.35	53	10.9" x 26.5"	29

* The last four digits of the Model No. identify the type of throttle. † Square drive accessories available (see above). Please specify the four digits when ordering: 0010 for Lever Throttle or 0030 for Safety Twist Throttle.

SDS Rotary Hammer Drills



Pneumatic and hydraulic: powerful percussion drilling for concrete and masonry

- SDS Plus or SDS Max models
- Safety clutch protects against overloading and jamming
- Hammer drill holes in concrete, brick and masonry
- Rotary drilling mode for straight drilling of steel and wood
- Open center hydraulic standard, closed center optional

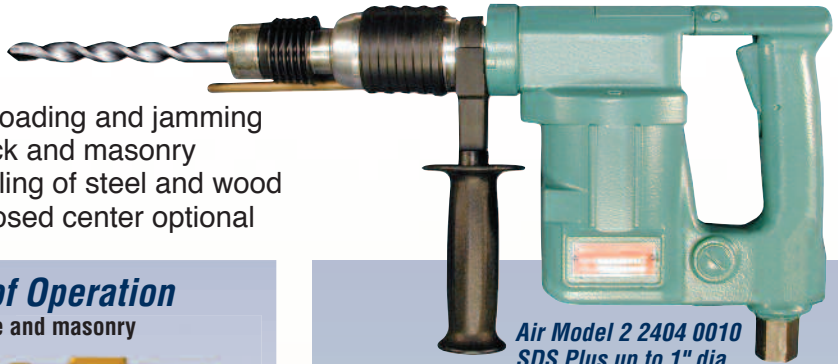

Air Model 2 2404 0010
SDS Plus up to 1" dia.

SDS Max – Two Modes of Operation

2" bit capacity for drilling concrete and masonry

Hammer with Rotation
Ideal for concrete drilling

Rotation Only For drilling steel and wood (not reversible)

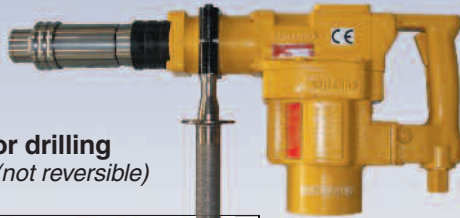

Air Model 2 2417 0010
SDS Max



Hydraulic Model
2 2418 0010
SDS Max

Second handle position

SAE #8 port for hydraulic hose connection

SDS Plus – Hammer and Drill

1" bit capacity for drilling concrete and masonry

Drill concrete anchor holes, thru holes, piping and mechanical openings for construction and repair work. Switches to rotary drilling mode for steel and wood.



Hydraulic Model
2 2406 0010
SDS Plus

SAE #8 oil port

Closed Center Flow Control Valve

Optional accessory – Part No. 38632



SDS Drill Bits



Small Masonry Bits
SDS Plus up to 1" dia.
Large Masonry Bits
SDS Max up to 2" dia.

Hydraulic Pressure Reducing Valves

PRV Part No. 2 2406 9970 reduces output pressure of standard hydraulic power units from 2000 PSI (140 bar) to 1160 PSI (80 bar). Included with SDS Plus Hydraulic Hammer Drill 2 2406 0020 and SDS Max Hydraulic Hammer Drill 2 2418 0020.



Pressure Reducing Valve Part No. 2 2406 9900 reduces the output pressure of larger-output hydraulic units (i.e. backhoes, large earth tractors, excavators, service trucks, etc.) from max. 5075 PSI (350 bar) to 1160 PSI (80 bar) working pressure.

Pneumatic Hammer Drill Model No.	Blows/Minute (BPM)	Drill Speed (RPM)	Solid Bit Capacity (Concrete)	Core Bit Capacity (Concrete)	Twist Drill (wood)	Power at 90 PSI	Air Consumption at 90 PSI	Tool System	Dimensions (inches)	Weight (lbs.)
2 1266 0010*	0-2000	0-950	1/2" dia.	1" dia.	3/8" dia.	0.75 HP	21 CFM	1/2" Chuck	12 x 8 1/2 x 4	7
2 2404 0010	0-3000	0-625	1" dia.	3" dia.	3/4" dia.	0.7 HP	21 CFM	SDS Plus	16 x 8 1/2 x 4	11
2 2404 0030*	0-3000	0-625	1" dia.	3" dia.	3/4" dia.	0.7 HP	21 CFM	SDS Plus	16 x 8 1/2 x 4	11
2 2417 0010*	0-2500	0-250	2" dia.	6" dia.	1 1/4" dia.	1.6 HP	53 CFM	SDS Max	19 1/2 x 9.8 x 4 1/2	26

* Underwater model – Optional underwater air tool line conditioner to displace moisture, Part No. MS 9105. See page 63.

Hydraulic Hammer Drill Model No.	Blows/Minute (BPM)	Drill Speed (RPM)	Solid Bit Capacity (Concrete)	Core Bit Capacity (Concrete)	Twist Drill (wood)	Power at 1160 PSI	Flow at 1160 PSI (GPM)	Tool System	Dimensions (inches)	Weight (lbs.)
2 2406 0010	0-3400	0-625	1" dia.	3" dia.	3/4" dia.	0.8 HP	5.8-13.2	SDS Plus	18 x 10 1/4 x 4	15
2 2406 0020	Same as above. Includes 2 2406 9970 Pressure Reducing Valve for 2000 PSI.									
2 2418 0010	0-2500	0-250	2" dia.	6" dia.	1 1/4" dia.	1.8 HP	2.6-13.2	SDS Max	19 1/2 x 11 1/8 x 7 1/2	37
2 2418 0020	Same as above. Includes 2 2406 9970 Pressure Reducing Valve for 2000 PSI.									

Hydraulic Hammer Drills operate at hydraulic pressures of 1160 PSI max. Pressure Reducing Valves are available to reduce pressure from 2000 PSI or 5000 PSI. See above. Available with optional closed center.

Woodboring Air Drills, Reversible

Heavy-duty power for underwater drilling and other wood boring applications

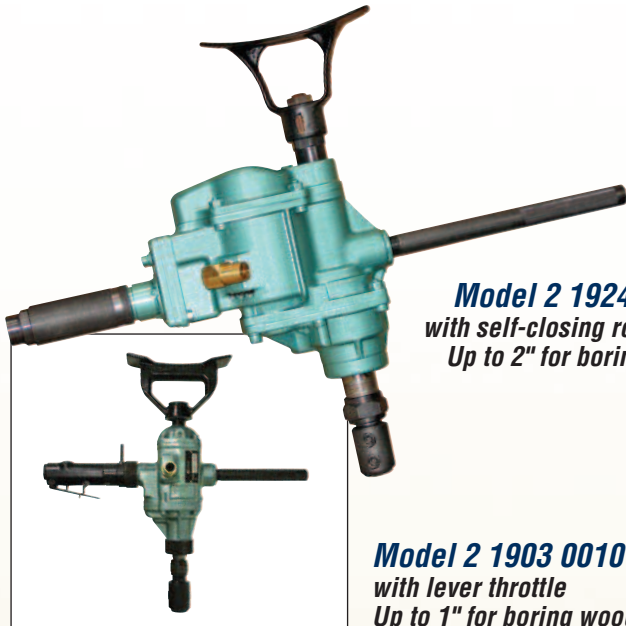

Model 2 1924 0010
with self-closing roll throttle
Up to 2" for boring wood

Model 2 1903 0010
with lever throttle
Up to 1" for boring wood

- Ideal for drilling wood in marine timbers, underwater use and railroad repair work
- Thrust bearing support for long life and efficient operation
- Lever throttle and durable spur gearing
- Breast plate and dead handle included
- Includes threaded exhaust port
- Use underwater with Air Tool Line Conditioner (shown below)

Accessories and woodboring drill bits from 1/2" dia. to 1 1/8" dia. in lengths from 12" to 36"

	Model 2 1903 0010	Model 2 1924 0010	Model 2 1932 0010
Capacity in Wood	1" Diameter	2" Diameter	3" Diameter
Reversible	Yes	Yes	Yes
Power	2 HP	3 HP	3 HP
Chuck Style	1/2" Woodboring	1/2" Woodboring	1/2" Woodboring
Spindle	Stub Taper	#2 Morse Taper	#3 Morse Taper
Free Speed	750 RPM	700 RPM	380 RPM
Recommended Hose Size	1/2"	1/2"	1/2"
Overall Height	17 1/2"	18 1/2"	18 1/2"
Weight	14 1/2 lbs.	24 3/4 lbs.	24 3/4 lbs.
Air Inlet Thread	1/2" ID	1/2" ID	1/2" ID
Air Exhaust Thread	1/2" NPT	1/2" NPT	1/2" NPT
Air Consumption at 90 PSI	39 CFM	50 CFM	50 CFM
Optional Geared Drill Chuck	Part no. DE-99C	Part no. IBC 22 (MT2)	Part no. IBC 21 (MT3)

AirPac Extends life of pneumatic power tools

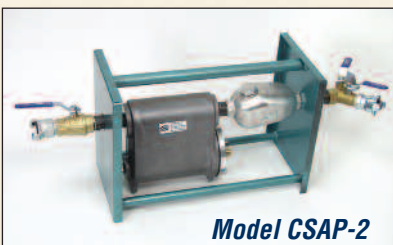

Model CSAP-2

- Removes moisture and dirt from air lines; a float valve automatically ejects water and dirt
- Includes automatic oiler; prevents tools from freezing in cold environments

- Eliminates air motor downtime caused by water and dirt
- Connections for two tools; max. air flow 185 CFM

Air Tool Line Conditioner

Underwater air tool conditioner for marine applications. Displaces moisture and inhibits rust/corrosion of air motors.

MS 9105 – 1 quart/liter



Nut Runners - High Torque



Pneumatic and hydraulic: ideal for turning valves, tightening, tapping, reaming, pipe beveling, expanding and more



- Worm gear drive provides high torque – up to 554 ft.-lbs.
- Lightweight and reversible
- Compact angle head allows access to confined spaces



**Model
6 1055 0075**

Model numbers pictured above (listed from top to bottom): **6 1055 0075** (with male drive), **6 1055 0010** (female), **6 1014 0075** (with male drive)

Available with Male or Female Square Drives, in a variety of sizes



Male Sq. Drive Head
1/2" or 3/4"



Female Sq. Drive Head
3/4" or 7/8"

Square Drive Accessories



- 3 6212 7910** – 3/4" Male Square Drive
- 6 1015 7940** – 1" Male Square Drive
- 6 1015 7030** – 3/4" Male Square Drive with retaining hole (included with model numbers 6 1014 0075, 6 1055 0075 and 6 1056 0075)
- 6 1017 7940** – 3/4" Male Square Drive with retaining pin



- 3 6339 4910** – 1/2" Male Square Drive with retaining hole (included with model numbers 6 1014 0099, 6 1055 0099 and 6 1056 0099)
- 6 1018 7940** – 1/2" Male Square Drive with retaining pin
- 6 1016 7940** – 1" Male Square Drive

Pneumatic Nut Runner Model No.	Square Drive F=Female M=Male	Stall Torque at 90 PSI (ft.-lbs.)	Free Speed (RPM)	Load Speed (RPM)	Power (HP)	CFM at 90 PSI	Side to Center Distance (inches)	Length (inches)	Weight (lbs.)	Air Conn-ec-tion (inches)	Hose ID (inches)
6 1014 0075*	3/4" M	95	200	100	0.9	46	1	22	11	NPT 3/8	1/2
6 1014 0099	1/2" M	95	200	100	0.9	46	1	22	11	NPT 3/8	1/2
6 1055 0075*	3/4" M	405	40	22	0.9	46	1	21	10	NPT 3/8	1/2
6 1055 0099	1/2" M	405	40	22	0.9	46	1	21	10	NPT 3/8	1/2
6 1056 0075*	3/4" M	133	120	67	0.9	46	1	21	11	NPT 3/8	1/2
6 1056 0099	1/2" M	133	120	67	0.9	46	1	21	11	NPT 3/8	1/2
6 1057 0075*	3/4" M	73.5	250	125	0.9	46	1	21	11	NPT 3/8	1/2
6 1057 0099	1/2" M	73.5	250	125	0.9	46	1	21	11	NPT 3/8	1/2
6 1061 0010	7/8" F	405	40	22	0.9	46	1	21	11	NPT 3/8	1/2

* Also available with 3/4" Female Square Drive – use 0010 instead of 0075 in model number.

Hydraulic Nut Runner Model No.	Square Drive F=Female M=Male	Drive Torque	Free Speed (RPM)	Load Speed (RPM)	Power (HP)	Oil Flow (GPM)	Oil Pressure (PSI)	Side to Center Distance (inches)	Length (inches)	Weight (lbs.)	Conn-ec-tion Quick Couplers
3 6242 0010*	3/4" F	369	40	22	1.6	4 - 13	90-2000	1	20	22	1/2" FF
3 6243 0010*	3/4" F	125	180	90	1.6	4 - 13	1300-2000	1	20	22	1/2" FF

* Also available with 1/2" (3 6242 0099) and 3/4" (3 6242 0075) Male Square Drive

Dry Cutting Circular Saws – Electric



Fast, clean, burr-free cutting of thin metal plates, pipes, profiles and more... without distortion!

Super Hand-Held Dry Cut Saw

12-5/8" diameter, dry cut up to 4-3/4" depth; up to 3/8" thick steel

- Largest portable dry metal cutting saw on the market
- Cuts steel, sandwich panels, I-beams, trapezoidal sheets, conduits, metal pipes and more – no deburring necessary
- High-quality tungsten carbide-tipped blade
- Side-mounted tilt tray for disposal of chips
- Motor protection with optical overload indicator
- Dust collection port for clean operation

Largest Hand-held Dry-cutting Metal Saw



8320 SHDC Super Hand-Held Dry Cut Saw (608270 U) standard equipment includes a saw blade (P/N 608276).



Integrated dust collection port

Order No. 608270 U

Motor Power	16 Amp/110V*
Blade Diameter	12-5/8" (325mm)
Max. Depth of Cut	4-3/4" (120mm)
Speed (Free)	1,400 RPM
Arbor Size	1"
Blade Part No.	608276 (12-5/8" dia.)**
Blade No. of Teeth	84T
Weight	21 lbs.

* 230V also available – Order No. 608270

** Blade for standard use.

For Stainless Steel blade, Order No. 608276T1, 84T

Super Hand-Held Accessory: Guide Rail with Clamping System

(P/N 608275 - shown at right)

Ideal for straight cutting of sandwich panels and sheets, guide rail and clamping system provides secure and jam-free guidance of saw blade through material. Rail provides straight edge length up to 55" (1,400mm).



**Non-sparking
Non-magnetic**

Also available at www.csunitec.com:

Pneumatic and Hydraulic High-Torque Drive Units

Non-Sparking and Non-Magnetic Safety Tools



Torque reaction stabilizers

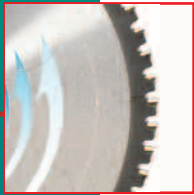

Dry Cutting Miter Saws – Electric

Fast, clean, burr-free cutting of thin metal plates, pipes, profiles and more... without distortion!

Dry Cut Miter Saw – 10" dia.



9410 ND Max. Cutting Capacities

	90° Cut	45° Cut
Round	2"	1.25"
Square	2"	1.25"
Rectangular	3.9" x 2"	2.36" x 1.25"

Precise 45° cuts left and right

- Cuts tubes, profiles and more from steel, stainless, non-ferrous metal, plastic, composite and more – no deburring necessary
- Fine cuts in soft and sensitive materials
- Adjustable saw head for miter cuts of -45° to +45°
- Secure clamping with 3-step quick-release system
- Lightweight and portable at only 42 lbs.

Order No. 608700

Motor Power	13 Amp/110V*
Blade Diameter	10" (255mm)
Max. Depth of Cut	4" at 90°
Speed (Free)	1,600 RPM
Arbor Size	1"
Blade Part No.	600598 (10" dia.)
Blade No. of Teeth	60T
Weight of Saw and Stand	42 lbs.

* 230V also available – Order No. 600651

9410 ND standard equipment includes a carrying case and saw blade (P/N 600598).

10" Saw Blades for 9410 ND
 P/N 600598, 60T, for mild steel
 P/N 600654, 66T, for thin steel
 P/N 600654TI, 66T, for stainless steel

Premium Super Dry Cutter – 14" dia.



Model 9435 Max. Cutting Capacities

	90° Cut	45° Cut
Round	5.5"	4.72"
Square	4.92"	3.15"
Rectangular	4.13" x 6.1"	2.95" x 3.93"

6" max. depth of cut

- Cuts stainless steel, ferrous and non-ferrous metal, plastic and aluminum tubes, profiles and more – no deburring necessary
- Exclusive blade stabilizing system reduces vibration
- Powerful, high-torque motor for continuous operation
- Patented quick-release vise for precise bevel cuts

Order No. 608301

Motor Power	15 Amp/110V*
Blade Diameter	14" (355mm)
Max. Depth of Cut	6" at 90°
Speed (Free)	1,600 RPM
Arbor Size	1"
Blade Part No.	600570 (14" dia.)
Blade No. of Teeth	90T
Weight	55 lbs.

* 230V also available – Order No. 600560



14" Saw Blades for Model 9435

P/N 600570, 90T
 for stainless and thin steel

P/N 600570SI, 96T
 for stainless steel

P/N 600580, 72T
 for stainless and medium steel

P/N 600590, 60T
 for stainless and thick steel

P/N 600591, 60T
 recommended for cast iron

P/N 600595, 66T
 recommended for mild steel

P/N 600594, 96T
 recommended for aluminum

Dry Cutting Circular Saws – Pneumatic

Air power ideal for foundries, petrochemical, marine, demolition and fabrication applications

7-1/2" dia. Heavy-Duty Air Saw

Cut up to 2-1/2" depth at 90° and 1-1/2" at 45°



- Heavy-duty air-powered circular saw, ideal for wet and dirty conditions
- Pneumatic power eliminates burn out from stalls
- Cuts up to 2-1/2" depth at 90° and 1-1/2" depth at 45°
- 7-1/2" max. blade capacity
- D-handle design with inside trigger and safety lock button to prevent accidental starting

Standard equipment includes rip fence and blade wrench. Blade not included.

Order No. 5 1116 0020

Motor Power	1.7 HP (1.3 kW)
Blade Diameter*	7-1/2" (190mm)
Max. Depth of Cut	2-1/2" at 90° / 1-1/2" at 45°
Speed (Free)	3,200 RPM
Air Consumption	53 CFM at 90 PSI
Air Connection	1/2" NPT
Vibration	<2.5 m/s ²
Length	13-1/2"
Weight	19 lbs.

* The Model 5 1116 0020 saw also accepts 7-1/4" dia. blades.

9" dia. Air Saw for 90° and 45° Cuts

Dry cut up to 3-1/4" depth and 3/8" thick steel plate



- Cut steel, non-ferrous metal, plastic, grating, composite and corrugated materials
- Cuts at 90° and 45° angles
- Ideal for petrochemical, marine, demolition and fabrication applications
- Cuts steel plate up to 3/8" thick

Order No. 5 1115 0020

Motor Power	2 HP (1.5 kW)
Blade Diameter	9"
Max. Depth of Cut	3-1/4" at 90° / 2-1/8" at 45°
Speed (Free)	1,700 RPM
Air Consumption	71 CFM at 90 PSI
Air Connection	1/2" NPT
Vibration	<2.5 m/s ²
Weight	19 lbs.

Standard equipment includes an impact-resistant carrying case and Ultra-thin LBS blade (P/N 722-23060).

Dry Cutting TCT Saw Blades

9" Laser Beam Saw (LBS) ultra-thin blade for all-purpose use features:

- Thinner than conventional saw blades: LBS = .055" vs. Std. = .073" thickness
- Shock-resistant, less vibration
- Produces 35% fewer chips

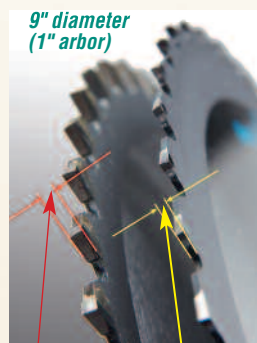

Standard blade .073" (1.85mm) thickness

Ultra-thin blade (P/N 722-23060) .055" (1.4mm) thickness



Part No.	Teeth	Thickness
722-23060*	60	.055"

* Standard with Model 5 1115 0020 Pneumatic Metal Saw.

Tungsten Carbide-Tipped Dry Cutting Blades 9" dia., .073" thick – for Model 5 1115 0020

P/N 721-23048, 48T, for standard use
 P/N 721-23060, 60T, for aluminum
 P/N 721-23068, 68T, for thin-wall metal
 P/N 721-23084, 84T, for sheet metal

12-5/8" dia. Air Circular Saw

Dry cut up to 4-3/4" depth and 3/8" thick steel plate



- Cut I-beams, 3/8" thick steel plate, insulation boards, sandwich panels, aluminum, plastics and more
- Suction nozzle and internal chip collector for clean operation
- D-handle design with inside trigger and safety lock button to prevent accidental starting
- 12-5/8" max. blade capacity

Order No. 5 1117 0020

Motor Power	2.4 HP (1.8 kW)
Blade Diameter	12-5/8"
Max. Depth of Cut	4-3/4"
Speed (Free)	1,200 RPM
Air Consumption	71 CFM at 90 PSI
Air Connection	1/2" NPT
Vibration	<2.5 m/s ²
Weight	24 lbs.

UNITEC ... the power of innovation!®

CS Unitec, Inc. specializes in industrial power tools and safety tools for construction and industry.

Innovation and high quality are synonymous with CS Unitec's power tools. In 1991, the company invented the first pneumatic portable band saw. CS Unitec has added to its list of industry firsts with the widest range of portable magnetic drills and hand-held concrete core drills. The line also includes surface preparation tools for metal, concrete and masonry, air, electric and hydraulic portable band saws, reciprocating saws, hack saws, nut runners, rotary hammer drills, rolling motors, non-sparking safety tools, portable mixers and dust extraction vacuum systems.

For tool specifications and ATEX and Ex Zone information, visit www.csunitec.com.

Call 1-800-700-5919 or 203-853-9522 to request any of the catalogs shown.



View demo videos at www.csunitec.com



Concrete Tools:

Surface Preparation Tools, Concrete Grinders, Dust Collection Systems, Diamond Core Drills, Air Concrete Saws and more

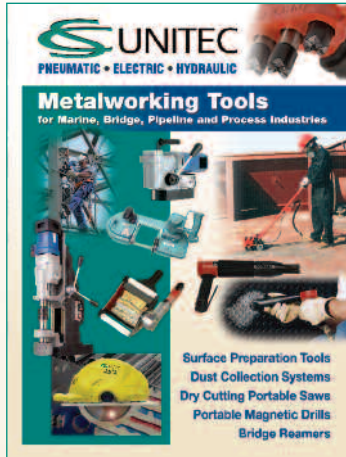

Metalworking Tools:

Surface Preparation Tools, Dust Collection Systems, Dry Cutting Portable Saws, Portable Magnetic Drills, Bridge Reamers and more

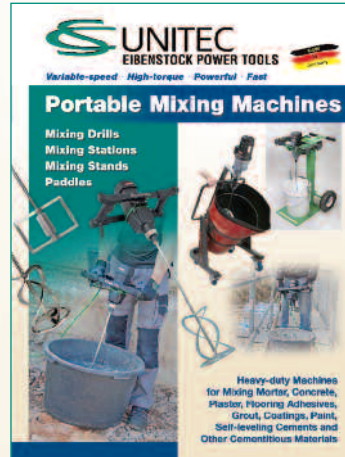

Portable Mixers:

Portable Mixing Machines for Mortar, Concrete, Plaster, Flooring Adhesives, Grout, Coatings, Paint, Self-Leveling Compounds and more



Portable Saws:

Hacksaws, Reciprocating Saws, Band Saws, Chain Saws, Cut-off Saws and more



Portable Magnetic Drills:

Magnetic Drills & Accessories Hand-held Drills and Drive Units Nut Runners Hammer Drills and more

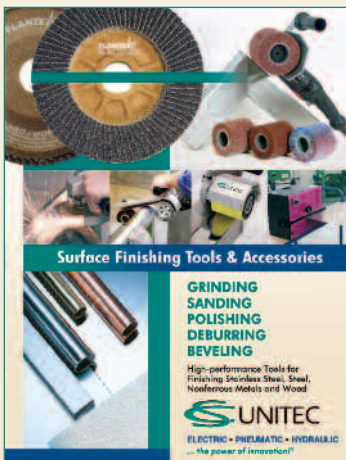

Surface Finishing Tools:

High-performance tools and accessories for grinding, sanding, polishing, deburring and beveling stainless steel, steel, nonferrous metals, wood and more



Non-sparking Hand Tools:

Non-sparking Hand Tools Power Tools for use in Ex Zones, ATEX Zones and Hazardous Environments



Concrete & Masonry Tools:

Power tools for the professional contractor to drill, cut, grind and smooth concrete, masonry, wood, drywall and more - includes dust collection tool systems



Distributed by:

Practical Tools Inc.

Aurora, Ontario - L4G 3H3

905-727-0014 / 888-847-8880

email: practicaltools@bellnet.ca



View product demonstrations at www.csunitec.com.

ALL SPECIFICATIONS ARE SUBJECT TO CHANGE

© Copyright 2015, CS Unitec, Inc., 09-15-10M